

sinopé

SW2500ZB

Installation guide

Smart Light Switch

Warnings

The installation of this light switch should be made by a certified electrician and must be installed in conformity with the national and local Electrical Codes.

This light switch requires a neutral wire. If your electrical box does not have a neutral wire, you can either add one or install the light switch at a different location.

YOUR SW2500ZB LIGHT SWITCH

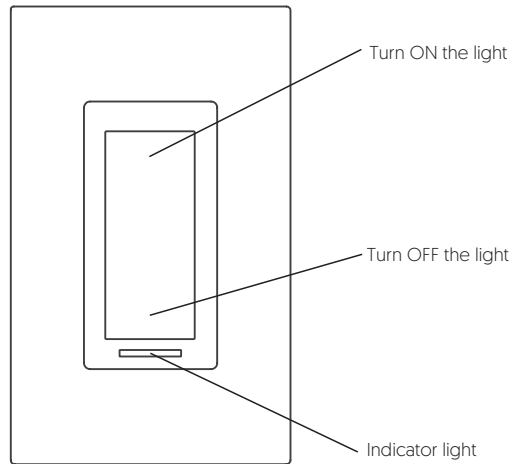

Light turned ON = Blue
Light turned OFF = Amber

The intensity of the indicator light can be changed from Neviweb and some compatible Zigbee gateways.

zigbee 3.0

SINGLE POLE WIRING DIAGRAM

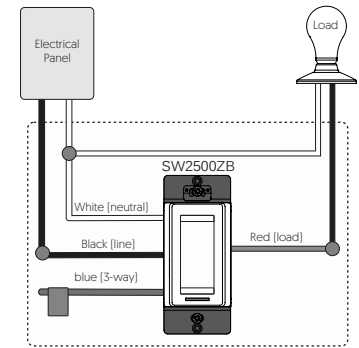

3-WAY WIRING DIAGRAM

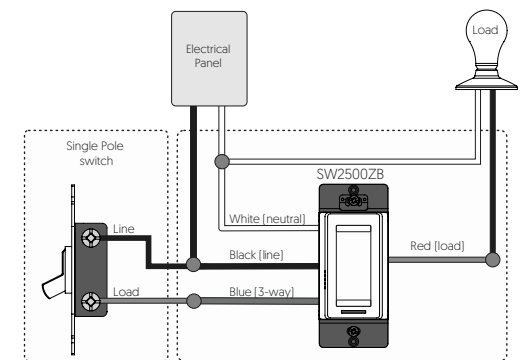

INSTALL YOUR LIGHT SWITCH

- 1 Make sure that the breaker for your switch is OFF at the main electrical panel then remove the old switch.

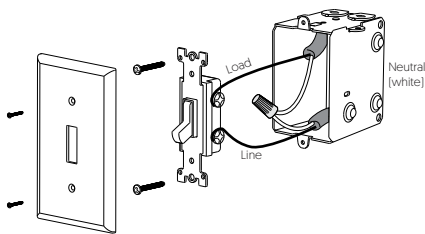

- 2 Use the provided connectors to connect the wires as follows:

Red	→	Load
Black	→	Line
White	→	Neutral
Blue	→	None*

***Note:** For a single pole installation, do not remove the label on the blue wire. For a 3-way installation, consult the 3-way wiring diagram on the next page.

Make sure to firmly tighten the wire connectors for a secure connection. A loose connection can be a fire hazard. Special CO/ALR solderless connectors must be used when connecting with aluminum conductors.

- 3 Use the provided screws to secure the light switch to the electrical box. Then, replace the wall plate.

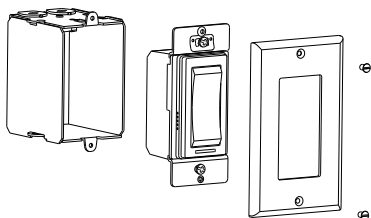

- 4 Power up the switch.

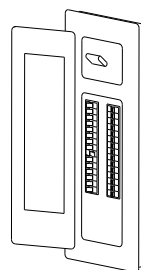

ADD YOUR SWITCH TO THE GT130 AND NEVIWEB

- 1 If you do not have an account yet, download the Neviweb app for iOS or Android to open an account and add your device.



- 2 Tap the then select "Add Device"



- 3 Follow the steps of the Installation Wizard

DISCONNECT YOUR LIGHT SWITCH FROM THE GT130 GATEWAY OR A COMPATIBLE ZIGBEE SYSTEM

To disconnect your light switch from the GT130 gateway or a compatible Zigbee system, press the 2 buttons of the light switch simultaneously for 10 seconds.

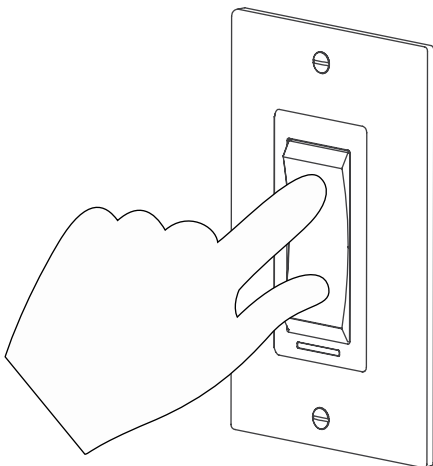

CONNECT YOUR LIGHT SWITCH TO A ZIGBEE COMPATIBLE SYSTEM

- 1 Initiate the connectivity session of your compatible Zigbee hub by referring to the device's user guide.



- 3 Connect all your compatible Zigbee devices the same way, by going to the next closest device.

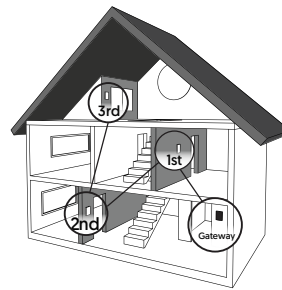

- 2 Connect your light switch to the network by pressing simultaneously the two dimmer buttons for 1 second.

On the switch: The indicator flashes blue when the device is connecting.

The indicator turns red = Failed
Refer to the "support" section of our Website to troubleshoot the unit.

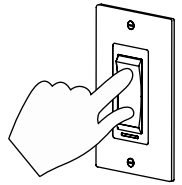

The indicator turns green = Connected
After a few seconds, the indicator changes color depending on the switch status.
[Turned ON = blue, Turned OFF = amber]

- 4 When all the devices are connected, close the connectivity session of your compatible Zigbee gateway.



TECHNICAL SPECIFICATIONS

Operating voltage: 120 Vac, 60 Hz
Operation temp.: 0 °C to 40 °C [32 °F to 104 °F]
Storage: -20 °C to 50 °C [-4 °F to 122 °F]
Standard UL: Conforms to ANSI/UL Std. 916
Standard CSA: Certified to CAN/CSA Std. C22.2 No205

PROVIDED CONNECTORS SPECIFICATIONS:

Stripping length: 16 mm
 Wires: 22-10 AWG, Cu
 Combinations: Max. 2 #12 & 2 #14, Min. 3 #20 Sol.



MAXIMUM LOAD:

450 W: LED, CFL, Halogen
600 W: Incandescent
1800 W: Resistive
1/2 HP: Ceiling fan

Zigbee 3.0 profile

Frequency: 2.4 GHz
Transmission power: +20 dBm
Receiver sensitivity: -108 dBm

Transmitter Module IC: 22394-ZBMI501 / FCC ID:2AK2T-ZBMI501
 This device complies with Industry Canada license exempt RSS standard[s].
 Operation is subject to the following two conditions:
 [1] this device does not cause interference, and [2] this device must accept any interference, including interference that may cause undesired operation of the device.
 This equipment has been tested and found to comply with the limits for a Class B digital device, pursuant to part 15 of the FCC Rules. These limits are designed to provide reasonable protection against harmful interference in a residential installation. This equipment generates, uses and can radiate radio frequency energy, and if not installed and used in accordance with the instructions, may cause harmful interference to radio communications. However, there is no guarantee that interference will not occur in a particular installation. If this equipment does cause harmful interference to radio or television reception, which can be determined by turning the equipment OFF and ON, the user is encouraged to try to correct the interference by one or more of the following measures:
 Reorient or relocate the receiving antenna.
 Increase the separation between the equipment and receiver.
 Connect the equipment into an outlet on a circuit different from that to which the receiver is connected.
 Consult the dealer or an experienced radio/TV technician for help.

3-year limited warranty

SINOPE TECHNOLOGIES INC. warrants the components of their products against defects in material and workmanship for a 3-year period from the date of purchase, under normal use and service, when proof of purchase of such is provided to the manufacturer. This warranty does not cover any transportation costs that may be incurred by the consumer. Nor does it cover a product that has been improperly installed, misused or accidentally damaged.
 The obligation of SINOPE TECHNOLOGIES INC., under the terms of this warranty, will be to supply a new unit and this releases the manufacturer from paying the installation costs or other secondary charges linked to replacing the unit or the components.