

sinopé

SP2610ZB

Installation Guide

Smart In-wall Outlet

zigbee HA 1.2

Warning

The installation of this in-wall outlet should be made by a certified electrician and must be installed in conformity with the national and local Electrical Codes.

Controllable devices should never be used to supply power to or control the ON/OFF status of medical and/or life support equipment.

INSTALL YOUR SMART IN-WALL OUTLET

This outlet can be used for a new installation or to replace an existing outlet. Indoor installation only.

- 1 Make sure that the breaker for your outlet is OFF at the main electrical panel then remove the old outlet.
- 2 Connect the outlet by using the terminal blocks, as shown in the wiring diagram. Black wire to the "Line" terminal block, white (neutral) wire to the "N" terminal block. Connect the ground wire (green) to the "G" terminal block.

Warning

Be sure to turn off the circuit from the electrical panel to avoid the risk of electric shock

Wiring Diagram

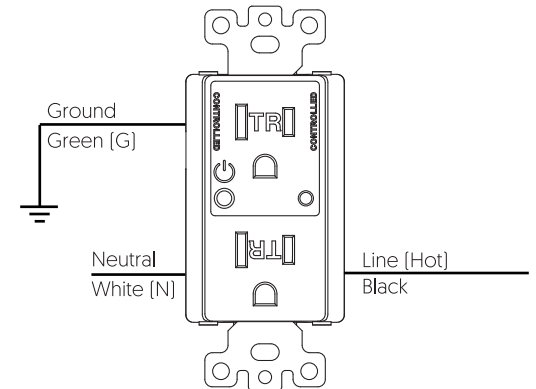

INSTALL YOUR SMART IN-WALL OUTLET (continued)

- 3 Use the provided screws to secure the outlet to the electrical box. Then, replace the wall plate.

- 4 Power up the outlet

Tighten terminal screws to 14 lbf-in
Use only 14 AWG copper or copper-clad wire with this device

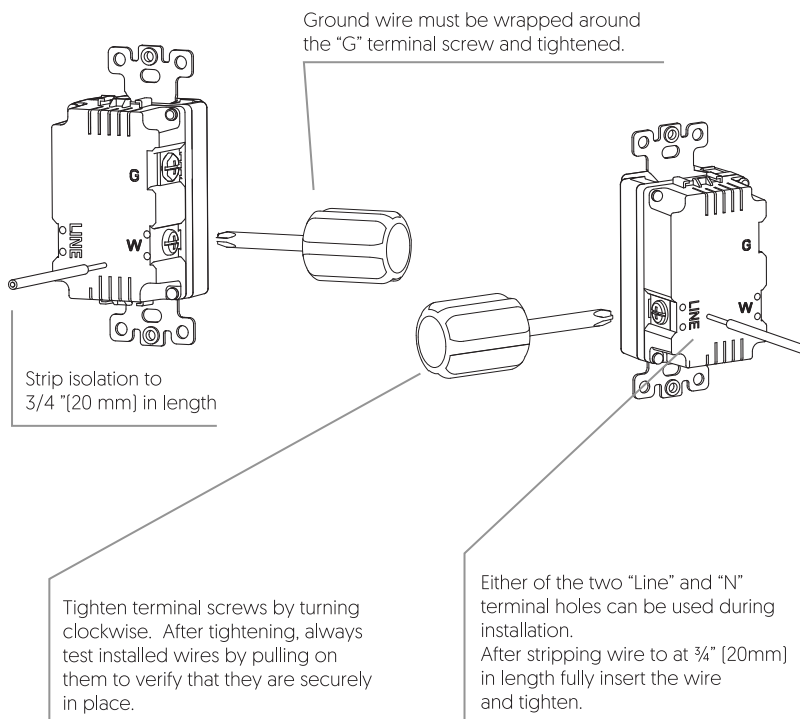

ADD YOUR SMART OUTLET TO THE GT130 GATEWAY AND NEVIWEB

- 1 If you do not have an account yet, download the Neviweb app for iOS or Android to open an account and add your device.



- 2 Tap the then select "Add Device"

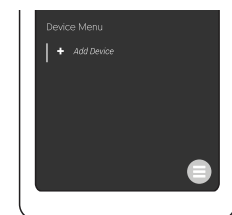

- 3 Follow the steps of the Installation Wizard

CONNECT YOUR SMART OUTLET TO A ZIGBEE COMPATIBLE SYSTEM

1

Initiate the connectivity session of your compatible Zigbee hub by referring to the device's user guide.



2

Connect the smart in-wall outlet to your network by pressing and holding the manual switch button.

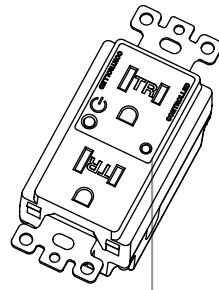

The connection status light
Blinks green: The outlet is connecting
Green: Connected

Note: If the smart outlet can not reach the gateway network after one minute, reset it and try again.

3

Connect all your compatible Zigbee devices the same way, by going to the next closest device.

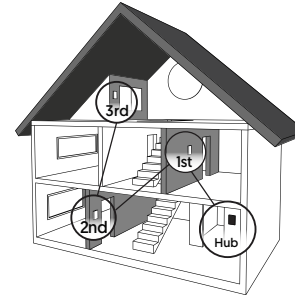

4

When your smart in-wall outlet is connected, close the connectivity session of your compatible Zigbee gateway.



Reset

Press and hold the On / Off button for six seconds.

(The indicator will remain ON for 10 seconds.)

TECHNICAL SPECIFICATIONS

Operating voltage: 120 VAC, 60 Hz

Operating ambient temperature:

0 °C to 40 °C [32 °F to 104 °F]

Storage: -20 °C to 50 °C [-4 °F to 122 °F]

UL standard: Conforms to UL 60730-1

CSA standard: Certified under CSA E60730-1

Maximum load

Incandescent: 960 W

Resistive: 15 A 1800 W

Electronic ballast: 500 VA

Motor: 0.5 HP

Zigbee HA 1.2 profile

Frequency: 2.4 GHz

Transmission power: +8 dBm

Indoor use only

OPERATIONS

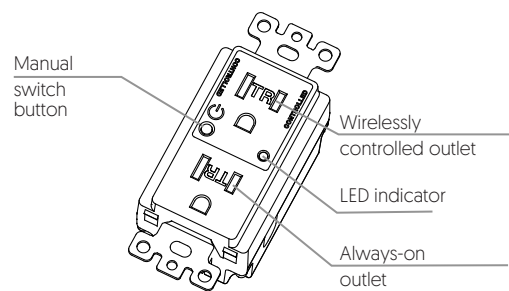

Manual control

The switch button on the outlet allows the user to:

Manually turn the connected device ON or Off by briefly pressing the button. When the LED indicator turns off, it means the remotely controllable outlet is OFF. When the LED turns green, it means that the controlled outlet is ON.

Transmitter module IC: 3653A-EM3585 / FCC ID: NHS-EM3585

This device complies with Industry Canada license exempt RSS standard(s). Operation is subject to the following two conditions: [1] this device does not cause interference, and [2] this device must accept any interference, including interference that may cause undesired operation of the device. This equipment has been tested and found to comply with the limits for a Class B digital device, pursuant to part 15 of the FCC Rules. These limits are designed to provide reasonable protection against harmful interference in a residential installation. This equipment generates, uses and can radiate radio frequency energy, and if not installed and used in accordance with the instructions, may cause harmful interference to radio or television reception. If this equipment does cause harmful interference to radio or television reception, which can be determined by turning the equipment OFF and ON, the user is encouraged to try to correct the interference by one or more of the following measures:

Reorient or relocate the receiving antenna.

Increase the separation between the equipment and receiver.

Connect the equipment into an outlet on a circuit different from that to which the receiver is connected.

Consult the dealer or an experienced radio/TV technician for help.

3-year limited warranty

SINOPE TECHNOLOGIES INC. warrants the components of their products against defects in material and workmanship for a 3-year period from the date of purchase, under normal use and service, when proof of purchase of such is provided to the manufacturer. This warranty does not cover any transportation costs that may be incurred by the consumer. Nor does it cover a product that has been improperly installed, misused or accidentally damaged.

The obligation of SINOPE TECHNOLOGIES INC., under the terms of this warranty, will be to supply a new unit and this releases the manufacturer from paying the installation costs or other secondary charges linked to replacing the unit or the components.