

sinopé | Pro

Smart thermostat

HVAC

Installation and Configuration Guide

TH6500WF



Table of contents

Table of contents	2
Included in the box	5
Installation requirements	5
Connections	6
System compatibility	7
Installation and configuration	8
Recommendations	8
Installation - TB6500 Connection module	9
Replacing an existing installation	9
Installation - Smart Wi-Fi thermostat TH6500WF	11
Preparation steps	11
TH6500WF installation	12
TH6500WF REV: 01 installation	14
Removing the thermostat from the wall	16
Configuration - Smart Wi-Fi thermostat TH6500WF	17
Option A - Configuration with the Sinopé Neviweb app	20
Option B - Configuration without Wi-Fi	22
Settings	23
Display options	23
Equipment configuration option	23
Summary of settings	28
System definition	30
Temperature controller	30
Conventional heating/cooling systems	30
Heat pump	31
Electric heating source SSR	31
Dual-energy	31
Accessories	31
Humidifier	32
Dehumidifier	32
Air exchanger	33
Air exchanger with integrated ventilation control	33

Thermal storage	33
User guide	34
Main screen	34
Menu	35
Interface	36
Wi-Fi connection	38
Wi-Fi connection with Sinopé	38
Association with Apple Home	41
Wi-Fi connection via Apple Home	43
Explore more with the Sinopé Neviweb app!	45
Troubleshooting and support	46
Warranty	47
3-year Limited Warranty	47
5-Year Extended Pro Warranty	47
Extended Pro Warranty Terms for Sinopé Pro Products	47
Technical information	48
Smart Wi-Fi thermostat for central system	49
Mounting plate - TH6500WF	50
Mounting plate - TH6500WF Rev: 01	51
Central system connection module	52
ISED Canada compliance statement	53
FCC compliance statement	53
Wiring diagrams	54
Conventional system	55
Wiring 1: 1H	55
Wiring 2: 1H	56
Wiring 3: 2H	57
Wiring 4: 1C	58
Wiring 5: 2C	59
Wiring 6: 1H1C	60
Wiring 7: 1H1C	61
Wiring 8: 1H2C	61
Wiring 9: 1H2C	63
Wiring 10: 2H1C	64
Wiring 11: 2H1C	65
Wiring 12: 2H2C	66
Wiring 13: 2H2C	67
Heat pump	68
Wiring 14: 1H1C	68

Wiring 15: 2H1C	69
Wiring 16: 2H1C	70
Wiring 17: 2H2C	71
Wiring 18: 3H1C	72
Wiring 19: 3H1C	73
Wiring 20: 3H2C	74
Wiring 21: 3H2C	75
Wiring 22: 4H2C	76
Wiring 23: 4H2C	77
Additional system	78
Wiring 24: Humidifier / Dehumidifier	78
Wiring 24.1: Humidifier / Dehumidifier	78
Wiring 24.2: Humidifier	79
Wiring 24.3: Thermal storage	79
Wiring 25: Air exchanger	80
Wiring 26: Dual-energy	80
Wiring 27: SSR	81
Wiring 28: Heat pump "L" output	81
Additional accessories	82
Decorative mounting plates	82
Decorative mounting plates for the TH6500WF	82
AC6500-01 Decorative Mounting Plate (sold separately)	82
AC6500-02 Decorative Mounting Plate (sold separately)	84
Decorative Mounting Plates for the TH6500WF REV: 01	86
AC6500-03 Decorative Mounting Plate (sold separately)	86
AC6500-04 Decorative Mounting Plate (included)	88

Included in the box

Inside the box, you will find:



TH6500WF thermostat



Mounting plate



TB6500 connection module



4x screws
4x anchors



Welcome guide

Installation requirements

- **Flathead or Phillips screwdriver** for wall installation of the mounting plate and connection module - Phillips #2/slot M7.0
- **Screwdriver for connectors**
 - Flathead screwdriver for the connection module wires - Slot M3.5 or 9/64", wire stripping length: 8-9mm
 - Flathead or Phillips screwdriver for thermostat wall plate wires - Phillips #1/slot M2.5, wire stripping length: 8-9mm
- **Optional** for easier setup:
 - Wi-Fi connection
 - Smartphone or tablet
 - Sinopé Neviweb account

Connections

LED	Connection	Description
	Th-Th	Communication with the thermostat (non-polarized)
	C	24 Vac common power supply
	R	24 Vac power supply from the heat pump
	Rh	24 Vac power supply from the furnace
X	G	Circulation fan
X	W1	First stage of heating or first stage of auxiliary heating
X	W2	Second stage of heating or auxiliary heating
X	O/B	Reversing valve
X	Y1	First stage of the heat pump or air conditioner
X	Y2	Second stage of the heat pump or air conditioner
X	ACC ACC	Connection for accessories. Used to connect additional accessories or external equipment
X	DE/L	Dual-energy signal input / "L" Heat Pump
X	C	24 Vac common power supply
X	HRV	Signal input indicating the air exchanger is running

System compatibility

#	Output / Input	Rh ¹	G	W1	W2	Y1	Y2	O/B	ACC	DE	HRV
Conventional system											
1	1H			X							
2	1H		X	X							
3	2H		X	X	X						
4	1C		X			X					
5	2C		X			X	X				
6	1H1C		X	X		X					
7	1H1C	X	X	X		X					
8	1H2C		X	X		X	X				
9	1H2C	X	X	X		X	X				
10	2H1C		X	X	X	X					
11	2H1C	X	X	X	X	X					
12	2H2C		X	X	X	X	X				
13	2H2C	X	X	X	X	X	X				
Heat Pump											
14	1H1C		X			X		X			
15	2H1C		X	X		X		X			
16	2H1C	X	X	X		X		X			
17	2H2C		X			X	X	X			
18	3H1C		X	X	X	X		X			
19	3H1C	X	X	X	X	X		X			
20	3H2C		X	X		X	X	X			
21	3H2C	X	X	X		X	X	X			
22	4H2C		X	X	X	X	X	X			
23	4H2C	X	X	X	X	X	X	X			
Additional system											
24	Humidifier, Dehumidifier, and Thermal storage								X		
25	Air exchanger								X		X
26	Dual-energy									X	
27	Electric SSR	See wiring diagram									
28	"L" Heat Pump	See wiring diagram									

¹ System with two transformers

Installation and configuration

Recommendations

It is highly recommended that you hire a qualified professional to ensure the safe and effective installation of the HVAC thermostat and the connection module to the HVAC system. Installing these components requires technical expertise and a thorough understanding of the applicable standards in your region.

- **Hire a qualified professional to install the HVAC system.**
- **Ensure system compatibility:** Before any installation, check that the components to be installed are compatible with your existing HVAC system. If in doubt, consult a professional for appropriate advice.
- **Follow applicable standards:** Ensure the installation complies with electrical and plumbing codes and regulations.

By following these recommendations and avoiding potential risks, you can ensure the safe and efficient installation of the HVAC thermostat and the connection module to your HVAC system. For your safety and the safety of those around you, hire a qualified professional.

Installation – TB6500 Connection module

Replacing an existing installation

The following steps describe how to upgrade an existing installation to improve efficiency and performance.

- 1 Evaluate the existing system.**
Assess the current HVAC system to understand its configuration and specifics.
- 2 Verify system compatibility**
Ensure the existing system is compatible with the available connections on the TB6500. If necessary, refer to the [connections](#) table.

- 3 Turn off the power.**
Before beginning the thermostat installation, make sure to power off the circuit from the electrical panel to avoid any risk of electrical shock.

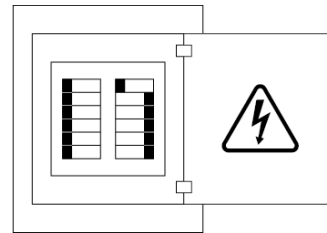

- 4 Attach the connection module** to the HVAC equipment frame or nearby wall.

Ensure the wires are long enough to reach the desired location.

Disconnect and/or cut the necessary wires to make the new connection to the connection module.

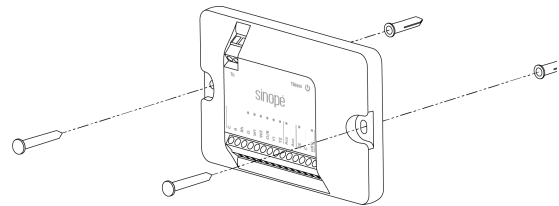

5

Select and connect 2 of the existing wires at the top of the connection module for communication with the thermostat.

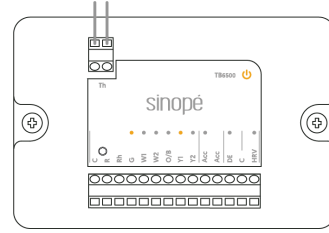

Note: Cable lengths should not exceed **30 meters (100 feet)** to ensure optimum communication between the **TH6500WF** and **TB6500**.

6

Connect the wires of your HVAC system to the connection module. Please refer to the wiring diagrams in the [Appendices](#) if needed.

Wire range Min/Max (Solid): 18-22 AWG
Wire range Min/Max (Stranded): 18-22 AWG

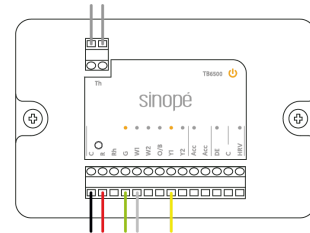

Tip

Take a photo of your wiring setup as a reference to simplify the installation and configuration of your thermostat.

7

Proceed with the installation of the TH6500WF thermostat

Continue with the next steps to install the [TH6500WF thermostat](#).

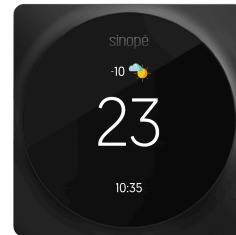

Installation – Smart Wi-Fi thermostat TH6500WF

Preparation steps

1

Switch off the power supply.

Before installing the thermostat, make sure that the breakers for your heating system are off at the electrical panel to avoid any risk of electric shock.

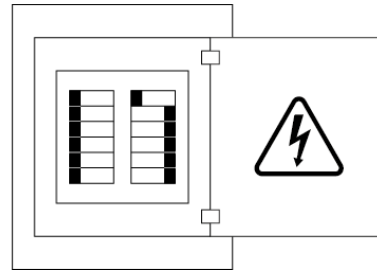

2

Remove the cover of your old thermostat.

Some covers can be removed by hand, while others may need to be unscrewed.

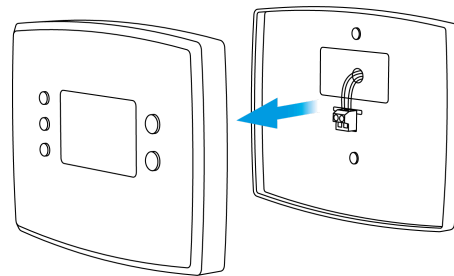

Warning

Check your system's compatibility.

If your old thermostat has a 120 V or 240 V label or features **thick wires with wire nuts**, it is a **high-voltage system**. Your system **is not compatible** with the TH6500WF thermostat.

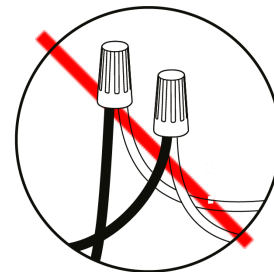

3

Take a photo of the wiring of your old thermostat.

This photo can be handy when installing your new thermostat, especially if it is installed before the TB6500 connection module.

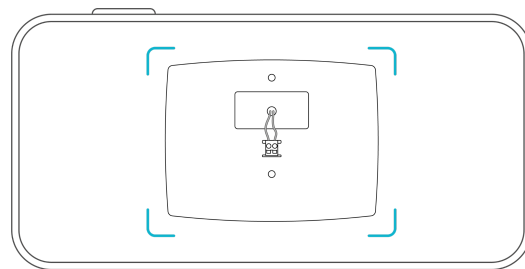

4

Disconnect the wires and remove the base.

After removing the base, we recommend gently wrapping the wires around a pen or pencil to prevent them from falling into the wall hole.

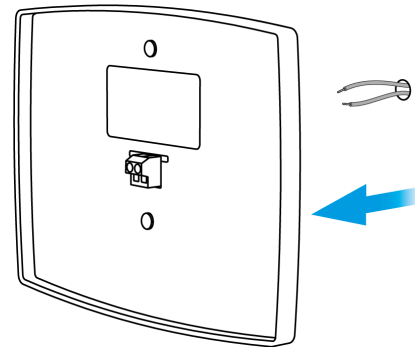

TH6500WF installation

1

Mark screw locations.

Use the spirit level on the mounting plate to ensure the thermostat is straight.

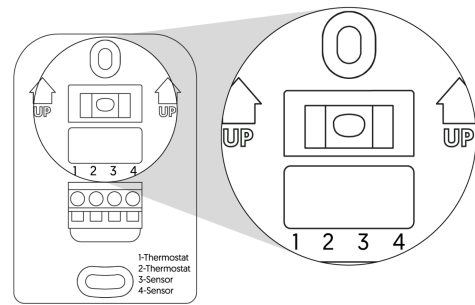

Installation Tip

When using the decorative mounting plate ([AC6500-01](#) or [AC6500-02](#)) to cover holes or marks left by a previous thermostat, install the decorative plate on the wall first. Then, attach the thermostat's wall plate on top.

⚠ Important note

If the installation includes a junction box, the decorative plate is **mandatory** to ensure **proper and safe coverage**.

2

Attach the mounting plate.

Feed the wires through the center of the base and secure it to the wall using the provided screws. Use anchors if needed.

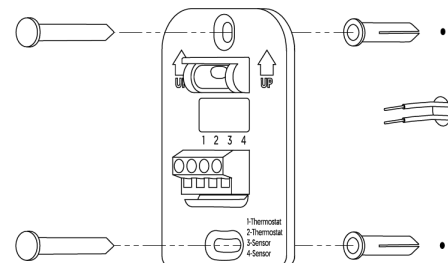

3

Connect the wires.

Insert each wire fully into the connector openings, then tighten the screws firmly to ensure a secure and stable connection.

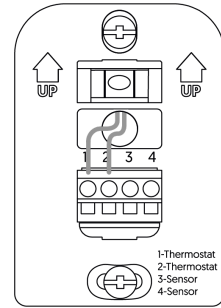

4

Attach the thermostat.

Align the thermostat with the wall plate and press it firmly until it clicks into place.

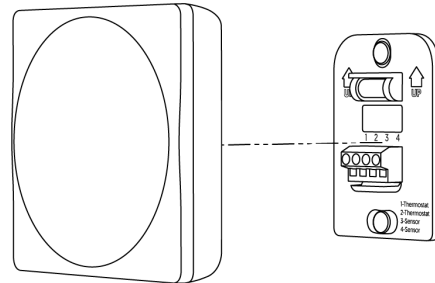

5

Restore power

Turn the circuit breaker back **ON** to power up the thermostat.

TB6500

The power light will turn on to confirm that the connection module is powered. Depending on your system's state, the LEDs of some activated outputs may also light up.

TH6500WF

The start-up screen will appear for a few moments.

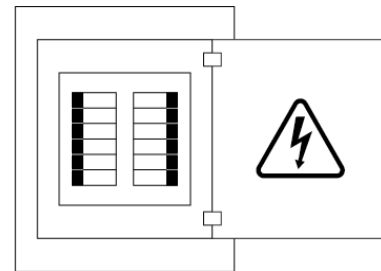

TH6500WF REV: 01 installation

1

Mark the screw locations.

Use a level to ensure the thermostat is properly aligned.

Installation Tip

When using the decorative mounting plate ([AC6500-03](#) or [AC6500-04](#)) to cover holes or marks left by a previous thermostat, install the decorative plate on the wall first. Then, attach the thermostat's wall plate on top.

⚠ Important note

If the installation includes a junction box, the decorative plate is **mandatory** to ensure **proper and safe coverage**.

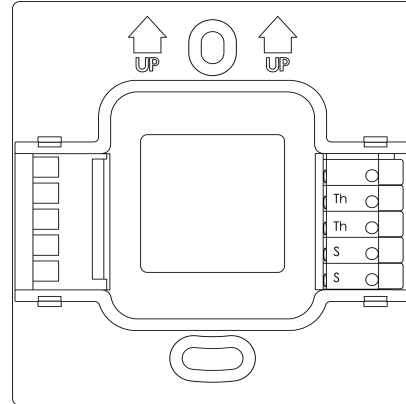

2

Attach the mounting plate.

Feed the wires through the center of the base and secure it to the wall using the provided screws. Use anchors if needed.

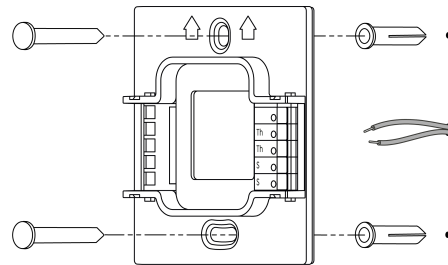

3

Connect the wires

Insert each wire fully into the connector.

Once all wires are properly connected, carefully tuck them into the wall cavity.

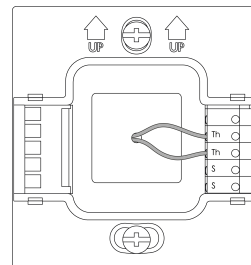

IMPORTANT

1. Insert the wires **through the sides** of the terminals, **not from the top**.

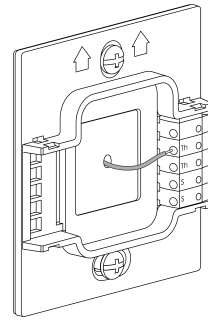

2. Carefully arrange the wires inside the wall so that they do not extend beyond the terminal block.

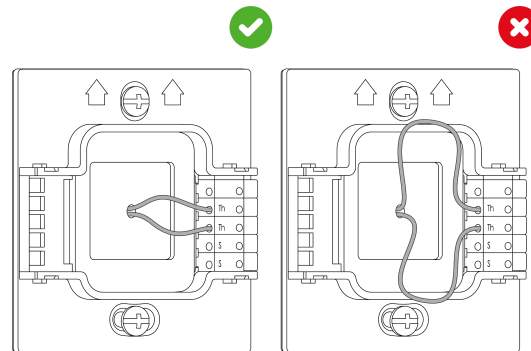

4

Attach the thermostat

Align the thermostat with the wall plate and press it firmly until it clicks into place.

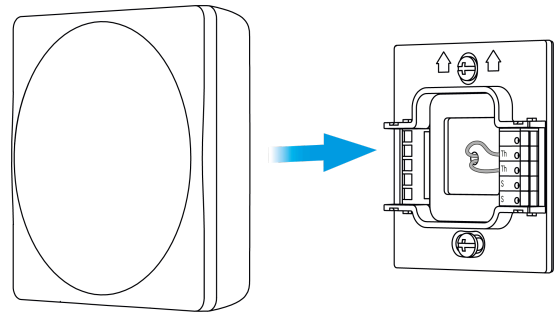

5

Restore power

Turn the circuit breaker back **ON** to power up the thermostat.

TB6500

The power light will turn on to confirm that the connection module is powered. Depending on your system's state, the LEDs of some activated outputs may also light up.

TH6500WF

The start-up screen will appear for a few moments.

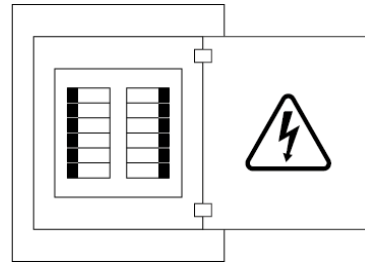

Removing the thermostat from the wall

To remove the thermostat from its wall base, follow these steps:

1. **Preparation:** Ensure you have a firm grip on both sides of the device.
2. **Removal:** Gently but firmly pull the thermostat toward you. The unit should snap off from the wall-mounted base.

Warning

Never insert any object (screwdriver, knife, or other tool) into the slots located under the thermostat to pry it off. This may cause serious damage to the device's internal components.

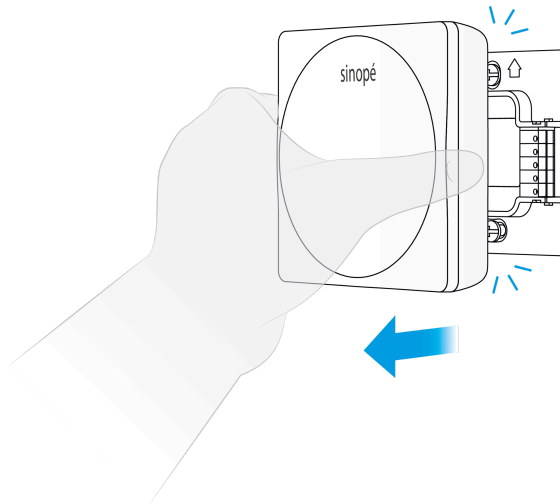

Configuration - Smart Wi-Fi thermostat TH6500WF

Once the thermostat is powered, the startup screen will briefly appear. Then, follow the steps below to configure it.

Startup screen



1

Language selection

Select the language for the thermostat display.



2

Temperature unit

Select the temperature format displayed on the thermostat screen.



3

Connections detected

Select the wires connected to the TB6500 connection module.

If the  symbol appears on a tile, click it to view error code details and learn how to fix the problem. If necessary, contact our [Support team](#).

Tip: Refer to the photo taken during the thermostat's installation.

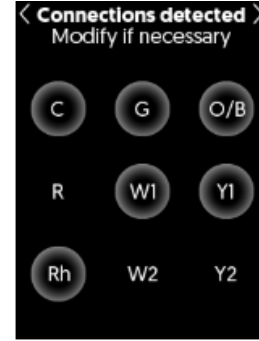

4

Input connection DE

Select your input connection DE, if applicable.

IMPORTANT: An external relay must be installed between the TB6500 and the heat pump to enable communication with the heat pump's "L" output. Refer to [wiring diagram 28](#).

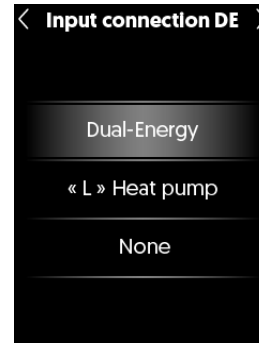

5

Accessories

Select your accessory, if applicable.



6

Reversing valve*

Determine whether the heat pump reversing valve is activated in cooling or heating mode.

* This screen is only available if the O/B wire is connected.

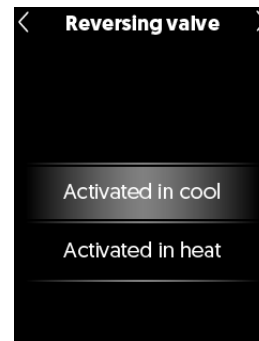

7

Balance point

Select the outdoor temperature above which your heat pump becomes ineffective.



8

Installation type *

Select the type of installation for your equipment

Add-On: If the auxiliary system is activated, the heat pump will be deactivated.

Conventional: The auxiliary system and heat pump can operate simultaneously.

* This screen is only available if the O/B wire is connected.

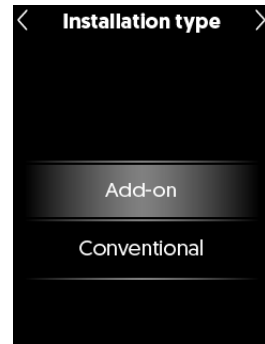

9

Your thermostat's basic configuration is now complete.

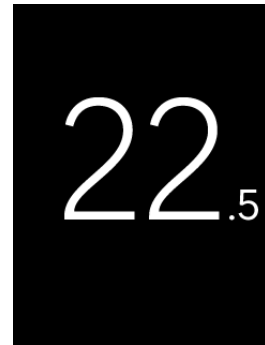

Two options are available for the next steps:

- A. Download the Sinopé Neviweb app to complete the configuration of your thermostat using your smartphone.



- B. Navigate the various equipment configuration menu settings to complete the installation.

Option A - Configuration with the Sinopé Neviweb app

The **Sinopé Neviweb** app lets you access all your smart thermostat's features and easily configure it from your smartphone.

1 Tap the thermostat screen to begin.

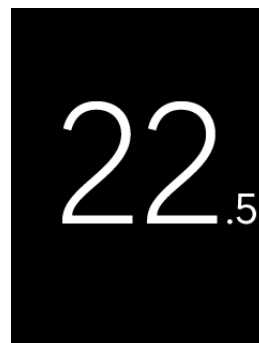

2 Tap the **Settings** icon (⚙️) to access the thermostat settings.

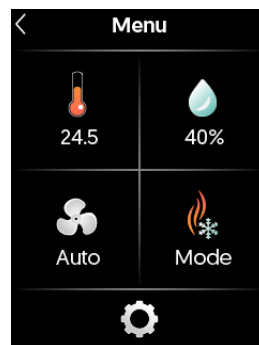

3 In the **Settings** menu, select **Wi-Fi connection**.

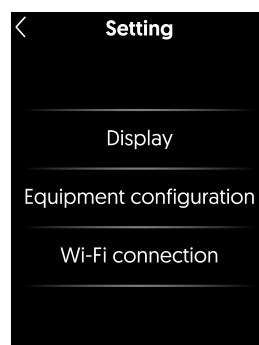

4 Select Sinopé as the configuration platform.

By choosing the **Sinopé Neviweb app**, you will be able to:

- Configure all your thermostat settings from your smartphone
- Display weather information directly on the thermostat screen
- Access advanced features within the Neviweb platform

You can also add your device to **Apple Home** later, if desired.

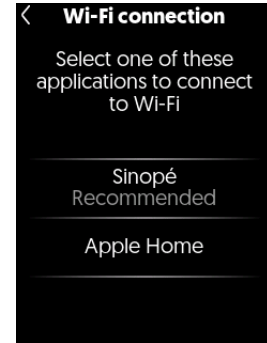

5 Follow the on-screen instructions to complete the Wi-Fi connection.

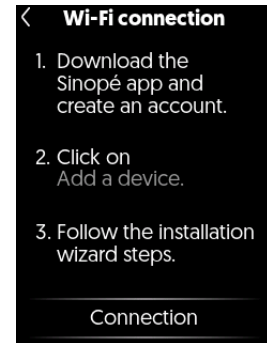

6 Once the Wi-Fi connection is complete, tap the thermostat tile in the Sinopé Neviweb app.

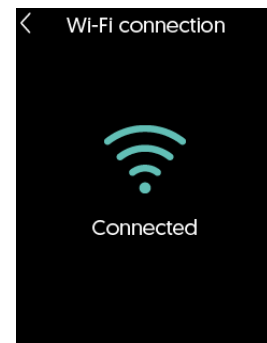

7

Configuring Settings in the App

In the app, tap the Settings icon (⚙️) to access the device settings.

Continue configuring your system by adjusting your preferences in the various menus.

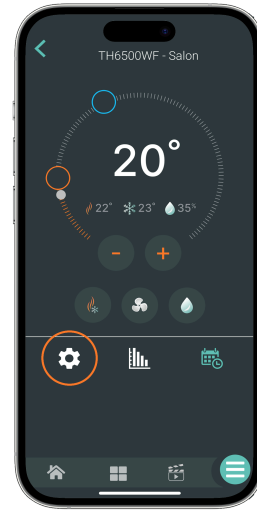

Option B – Configuration without Wi-Fi

Several settings of your new thermostat can be configured directly from its interface.

1

Tap the thermostat screen to begin.

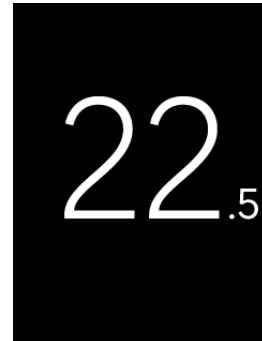

2

Tap the **Settings** icon (⚙️) to access the thermostat settings.

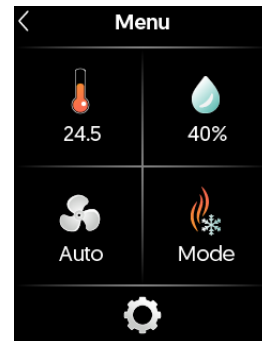

3

In the **Settings** menu, select a submenu to customize the device.

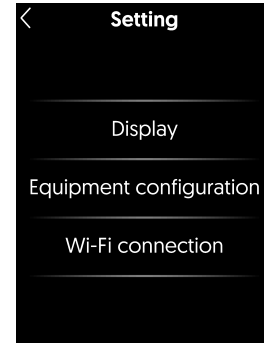

Settings

Display options

Default value in **bold**.

Settings	Description	Options
Temperature unit	Temperature format featured on the thermostat display.	Celsius Fahrenheit
Language	Language displayed on your thermostat.	Français English

Equipment configuration option

Some settings may not be available on your thermostat. Access to these settings varies depending on your system.

Warning: We recommend that the configuration be performed by a professional.

Default value in **bold**.

Settings	Description	Options
Heating source W1	Type of energy used for heating source W1. <ul style="list-style-type: none"> • Electric: System powered by electricity. • Fossil: System powered by a fossil fuel, such as gas or fuel oil. • VRF: Heating, fan, and cooling system that uses a variable speed compressor. 	Electric Fossil VRF

Settings	Description	Options
Heating source W2*	Type of energy used for heating source W2. <ul style="list-style-type: none"> • Electric: System powered by electricity. • Fossil: System powered by a fossil fuel, such as gas or fuel oil. • SSR: Heating system using a semiconductor relay. *If you have an electric baseboard heater equipped with a non-SSR relay, select the "Fossil" option instead of "Electric."	Electric Fossil Electric SSR
Auxiliary heating source*	Type of energy used for the auxiliary heating source <ul style="list-style-type: none"> • Electric: System powered by electricity. • Fossil: System powered by a fossil fuel, such as gas or fuel oil. • SSR: Heating system using a semiconductor relay. *If you have an electric baseboard heater equipped with a non-SSR relay, select the "Fossil" option instead of "Electric."	Fossil Electric Electric SSR
Reversing valve	Determine if the heat pump reversing valve is activated in cooling or heating mode.	Activated in cool Activated in heat
Input connection DE	Select your input connection DE, if applicable. Refer to wiring diagram 26 or 28 .	Dual-Energy "L" Heat pump None
Accessories	Select your accessory, if applicable.	None Humidifier Air exchanger Dehumidifier Thermal storage
Heat dissipation time	Delay that allows hot air remaining in the ducts to be evacuated after the system has been shut down.	1 min 2 min 3 min 4 min 5 min Off
Cool dissipation time	Delay that allows cold air remaining in the ducts to be evacuated after the system has been shut down.	1 min 2 min 3 min 4 min 5 min Off
Cooling cycle length in Y	The thermostat adjusts the control band to achieve the desired cooling cycle length. A shorter cycle will increase your comfort but will also increase the wear of your equipment.	25 min 20 min 15 min 10 min

Settings	Description	Options
Heat pump cycle length	The thermostat adjusts the control band to achieve the desired cycle length of your heat pump. A shorter cycle increases your comfort but accelerates wear and tear on your equipment.	25 min 20 min 15 min 10 min
Heat cycle length in W1	The thermostat adjusts the control band to achieve the desired heating cycle length. A shorter cycle will increase your comfort but will also increase the wear of your equipment.	25 min 20 min 15 min 10 min ^{2*}
Auxiliary cycle length	The thermostat adjusts the control band to achieve the desired heating cycle length. A shorter cycle will increase your comfort but will also increase the wear of your equipment. If you use an SSR heating source and select a 15-second delay, ventilation will not be activated (e.g. baseboard). If you select a 1-second delay, ventilation will be activated according to the requested mode (e.g. duct heater).	25 min 20 min 15 min 10 min ³ 1 sec ** 15 sec **
Heat cycle length in W2	The thermostat adjusts the control band to achieve the desired heating cycle length. A shorter cycle will increase your comfort but will also increase the wear of your equipment. If you use an SSR heating source and select a 15-second delay, ventilation will not be activated (e.g., baseboard). If you select a 1-second delay, ventilation will be activated according to the requested mode (e.g., duct heater).	25 min 20 min 15 min 10 min ^{2*} 1 sec ** 15 sec **
Heating/Cooling setpoint Delta T°	The minimum temperature delta authorized between the heating and cooling setpoints. Only applies in AUTO mode.	1 °C 2 °C 3 °C 4 °C 5 °C
Balance point	Outdoor temperature at which the heat pump is no longer efficient. <i>Note that this setting is also available if you have 2 stages of conventional heating, to support a VRF installation with an auxiliary heating stage.</i>	-30 °C to 0 °C Off Default: -15 °C

^{2*}Not available when the heating source is set to Fossil.

** Available for SSR heating source only

³ Available only when the selected heating source is electric

Settings	Description	Options
Air curtain⁴	<p>Adjust the output of SSR heating systems (e.g., electric baseboard) according to the outdoor temperature – the colder it is, the higher the output – to avoid the sensation of cold near windows.</p> <p>Outdoor temperature Activation: Outdoor temperature at which the SSR heating source activates at minimum output.</p> <p>Outdoor temperature Maximum power: Outdoor temperature at which the SSR heating source reaches full power.</p>	<p>Off</p> <p>Outdoor T° Activation: 0°C</p> <p>Outdoor T° Max. power: -50°C</p> <p>Option: 10°C to -50°C</p>
Installation type	<p>Installation type of your equipment</p> <p>Add-On: If the auxiliary system is activated, the heat pump will be deactivated.</p> <p>Conventional: The auxiliary system and heat pump can operate simultaneously.</p>	<p>Add-On</p> <p>Conventional</p>
Temperature calibration	<p>Temperature offset needed to compensate for the inaccuracies between the thermostat temperature reading and the ambient temperature.</p>	<p>2 °C</p> <p>1.5 °C</p> <p>1 °C</p> <p>0.5 °C</p> <p>0 °C</p> <p>-0.5 °C</p> <p>-1 °C</p> <p>-1.5 °C</p> <p>-2 °C</p>
Compressor min. run time	<p>Minimum time for which the compressors will be active before they can be switched off.</p>	<p>2 min</p> <p>3 min</p> <p>4 min</p> <p>5 min</p> <p>10 min</p>
Compressor min. off time	<p>Minimum time the compressor must be switched off before restarting.</p>	<p>2 min</p> <p>3 min</p> <p>4 min</p> <p>5 min</p> <p>10 min</p>
Auxiliary heating min. run time	<p>Minimum time the auxiliary heater will run before it can be switched off.</p>	<p>2 min</p> <p>3 min</p> <p>4 min</p> <p>5 min</p> <p>10 min</p>
Heating min. off time	<p>Minimum time the main heater must remain off.</p>	<p>2 min</p> <p>3 min</p> <p>4 min</p>

⁴ Available if an SSR heating source is selected.

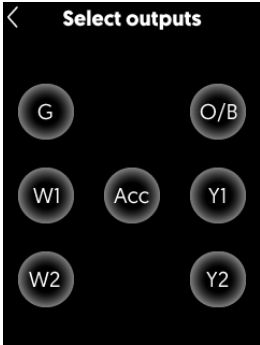
Settings	Description	Options
		5 min 10 min
Auxiliary heating min. off time	Minimum time the main heater must remain off.	2 min 3 min 4 min 5 min 10 min
Heat pump try time	The period for which the heat pump is used to regulate the temperature before the auxiliary heat stage can be activated.	30 min 1 h 2 h 3 h 4 h 5 h 6 h 7 h 8 h
W1 Try time	The period for which the output W1 is used to regulate the temperature before the output W2 can be activated.	15 min 30 min 45 min 1 h 2 h 3 h 4 h 5 h 6 h 7 h 8 h
Polarity of W outputs	The polarity setting for the W outputs lets you specify whether the output is normally open or normally closed.	Normally open Normally closed
Equipment testing	<p>This tool allows the installer to test the equipment. Testing should be conducted by a qualified professional. Improper testing could damage the equipment.</p> <p>Pressing 'Continue' will display the available outputs. The professional can then select one or more outputs. The system will activate automatically based on the selected outputs. To end the test, press the output again to deactivate it.</p> <p>If the  symbol appears on a tile, click it to view error code details and learn how to fix the problem. If necessary, contact our Technical Support team.</p>	
Diagnostic	This page displays various information that may be useful if you need to contact our Technical Support team. No configuration is possible from this screen.	

Settings	Description	Options
Factory reset	<p>Two possible options:</p> <p>Equipment configuration: Resets equipment-specific parameters and wire configuration. Other parameters, such as temperature format, setpoints, schedules, and Wi-Fi connection, will remain unchanged.</p> <p>Device Reset: Resets all custom data and previous settings, allowing the user to restart the installation process from scratch.</p>	

Summary of settings

	TH6500WF	Sinopé app
Display		
Temperature unit	X	
Language	X	
Device Configuration		
Temperature unit	X	X
Language	X	X
Time format		X
Screen brightness		X
Screen access		X
Filter change reminder		X
Away heating setpoint		X
Away cooling setpoint		X
Dual-energy optimization - Éco Sinopé		X
Accessory optimization - Éco Sinopé		X
Maximum setpoint heating		X
Minimum setpoint heating		X
Maximum setpoint cooling		X
Minimum setpoint cooling		X
Early start		X
Do not allow heating if the outside temperature is above X°C.		X
Do not allow cooling if the outside temperature is below X°C.		X
Equipment configuration		
Heating source W1	X	X
Heating source W2	X	X
Auxiliary heating source	X	X
Reversing valve	X	X

	TH6500WF	Sinopé app
Input connection DE	X	X
Accessories	X	X
Heat dissipation time	X	X
Cool dissipation time	X	X
Cooling cycle length Y	X	X
Heat pump cycle length	X	X
Heating cycle length W1	X	X
Auxiliary heating cycle length	X	X
Heating cycle length W2	X	X
Heating/Cooling setpoint Delta	X	X
Installation type	X	X
Balance point	X	X
Air curtain	X	X
Temperature calibration	X	X
Compressor min. run time	X	X
Compressor min. off time	X	X
Auxiliary heating min. run time	X	X
Heating min. off time	X	X
Auxiliary heating min. off time	X	X
Heat pump try time	X	X
W1 try time	X	X
Minimum delay before activation of an additional heating stage	X	X
Minimum delay before activation of an additional cooling stage	X	X
Polarity of W outputs	X	X
Equipment testing	X	
Diagnostic	X	
Factory reset	X	

System definition

Temperature controller

The TH6500WF uses an adaptive deadband controller with a programmable cycle length. The thermostat's control band automatically adjusts to achieve the desired cycle length for your system.

Note: The control band represents the range between the room's maximum and minimum temperatures when the system operates at 50% power, which directly affects comfort.

Since different cycle lengths can be set for primary heating, auxiliary heating, and cooling, the thermostat adjusts to optimize each of the three modes. The thermostat may require several control cycles before adjusting to optimal values. Once optimized, the thermostat saves the optimal value to immediately know which control band to use upon mode change or product restart. The cycle length is 15 minutes by default, but this setting can be changed in the advanced configuration menu.

For example, a thermostat set to a 15-minute cycle may initially only achieve an 18-minute cycle at startup. The thermostat will adjust the control band until the desired cycle time is reached.

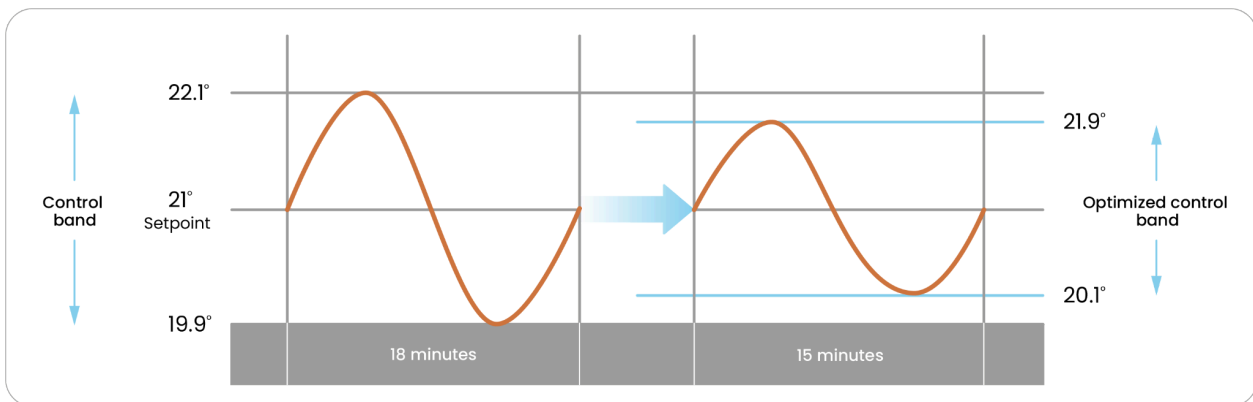

While setting a very short control cycle to increase comfort may be tempting, this approach should not be prioritized. It is essential to set the control cycle according to the installed equipment. Subsequently, the thermostat will automatically optimize the control band to maximize comfort.

Conventional heating/cooling systems

Conventional heating systems supported include furnaces (gas, oil, or electric), air conditioners, hydronic heating systems, radiant floors, fan coils, and electric heaters⁵.

⁵ A high-voltage relay is required to activate a load powered by a voltage higher than 24V.

The thermostat can control up to 2 heating stages, 2 cooling stages, a fan, and an accessory. When changing setpoints, the thermostat waits for the **'Minimum delay before activation of an additional heating stage'** before activating an additional stage.

Two different heating sources can be used. To prioritize one source over the other, connect the primary source to W1 and the auxiliary source to W2 and configure them as different types of heating sources. W2 will be used either in the event of a significant temperature drop or within a dual-energy system. The **'W1 try time'** setting determines how long W1 will be used before switching to W2 to bring the temperature back to the setpoint.

Heat pump

The thermostat supports up to 4 heating stages (2 heat pumps and 2 auxiliary heating), 2 cooling stages, a fan, and an accessory.

The thermostat activates the auxiliary heating stage only if the room temperature exceeds twice the control band (calculated by the thermostat's adaptive controller; see the "Temperature controller" section) for longer than the **'Heat Pump Try Time'**, an adjustable parameter in the advanced settings. This feature prioritizes heat pump operation while providing freeze protection in the event of failure. If the outdoor temperature drops below the adjustable 'Balance Point' in advanced settings, the heating switches to auxiliary heating, and the heat pump is stopped.

If you have connected the "L" wire of your heat pump to the **DE** input, a message will appear on the thermostat in the event of a heat pump error. Refer to [wiring diagram 28](#)

Electric heating source SSR

To avoid wide temperature variations, the thermostat can be configured with a rapid control cycle for secondary heating, either for an electric baseboard (15 seconds) or a coil (1 second). This type of installation requires the use of an SSR-type electronic relay. Refer to the [wiring diagram 27](#).

Dual-energy

The **'DE'** dual-energy input can be connected to a dry contact from a dual-register electric meter or any other device requiring auxiliary heating.

An auxiliary heating output is required to access this feature. When the dual-energy input is activated, the thermostat will exclusively use the heating connected to the auxiliary heating stage.

Accessories

If you connect an accessory to the **'ACC'** output, it is important to select the thermostat's control mode correctly during installation. You can always adjust it later in the equipment configuration menu.

Humidifier

If you have a bypass humidifier, whether pad- or drum-type, you must select '**Humidifier on Heat**' in the accessory settings. The thermostat will activate the humidifier water valve only when the heating is running and humidification is needed. This ensures proper water vapor distribution and prevents condensation in the ducts.

If you have a steam humidifier, select '**Humidifier on Fan**' in the accessory settings. The thermostat will activate the humidifier only if the ventilation is activated and humidification is needed.

The thermostat offers two humidity management modes: **Automatic** and **Manual**.

- **Manual mode:** Allows you to manually select the desired humidity level (in %). The system will maintain this level regardless of the outside temperature.
- **Automatic mode:** The humidity level is automatically adjusted based on the outside temperature. This approach optimizes comfort while reducing the risk of condensation, particularly on windows during cold periods. The curve used to determine the humidity percentage in automatic mode is based on the following reference: *ASHRAE HVAC Handbook, Chapter 22 – Table 1: Maximum Relative Humidity in a Space for No Condensation on Windows*⁶.

You can also apply an offset in **Auto mode** to lower the target humidity level further, helping to prevent excessive condensation.

Auto and **Manual** mode management is also available for **dehumidification** and the **air exchanger**.

Dehumidifier

A dehumidifier can be connected to the thermostat to control the home's humidity level. The ventilation and dehumidifier will activate automatically at the same time. The option of manual or automatic control also applies to the humidifier.

⁶ https://www.ashrae.org/file%20library/technical%20resources/covid-19/si_s20_ch22.pdf

Air exchanger

After selecting this accessory, you can force air exchange from the home menu by choosing one of the following options:

Option	Description
OFF	No air exchange
20 min/h (default)	20 min air exchange every hour
40 min/h	40 min air exchange every hour
Continuous	Continuous air exchange

The air exchanger can also be used to **control humidity levels**. If the humidity inside the home is too high and outdoor conditions allow, the exchanger will be activated to dehumidify the air based on the set point defined in the parameters—either in automatic or manual mode, as mentioned above.

Air exchanger with integrated ventilation control

If your air exchanger includes a ventilation control output, it can be connected to the **HRV** input to activate the HVAC system's ventilation.

Thermal storage

A thermal storage unit can be connected to participate in peak demand events. Heat is stored ahead of a peak event and used during the event to maintain optimal user comfort.

User guide

Main screen



Note: The outdoor temperature, weather conditions, and time are available if the thermostat has been added to the Sinopé application.

Menu

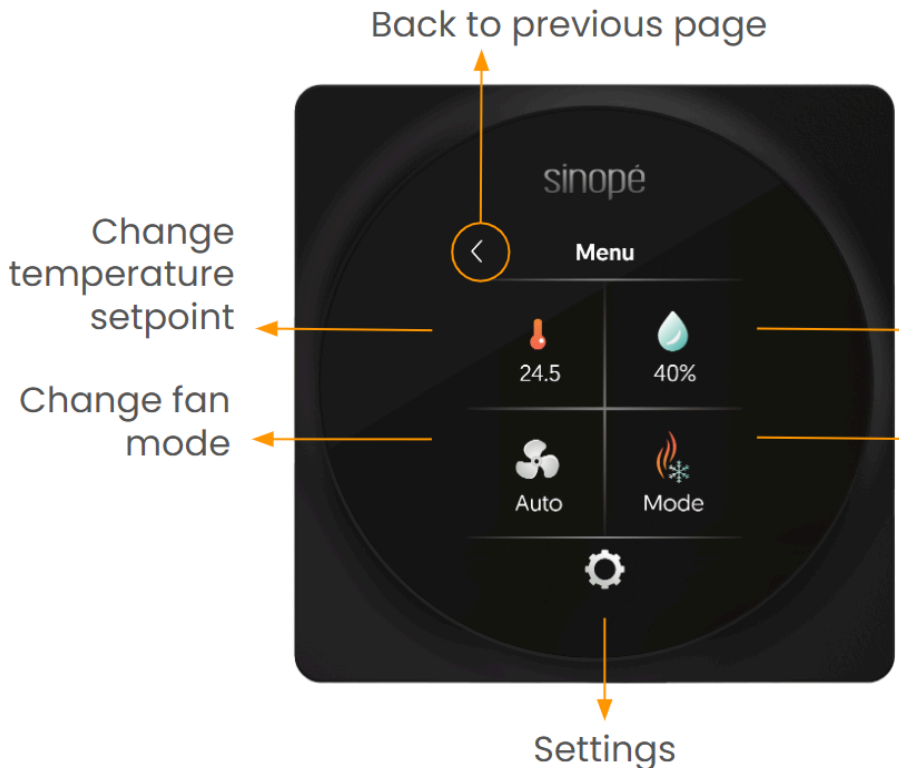
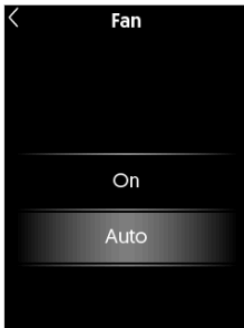
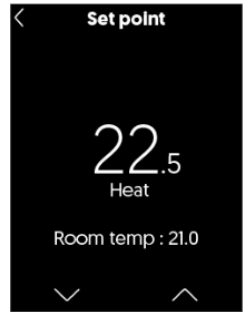

Modify the status of your accessory
If no accessory is connected, only the humidity level in the home will be displayed.

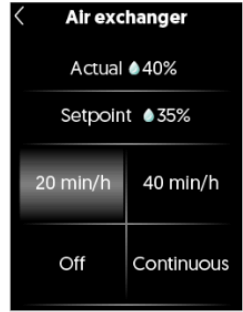

Change modes
The modes displayed may vary depending on the system.



Interface



Your system is currently cooling



Your system is presently heating



Your system is in auxiliary heating mode



Your system is in dual-energy mode



Your device takes part in a peak event



Thermostat: Wi-Fi connection lost



An error is detected. Press the screen to obtain details



Outdoor temperature settings prevent system activation

Wi-Fi connection

You can connect your thermostat to Wi-Fi in two ways:

- Set up with the **Sinopé Neviweb** app
- Set up with **Apple Home**

We recommend starting with the setup through the Sinopé Neviweb app. This platform lets you easily configure all your thermostat settings on your smartphone. Additionally, the Sinopé Neviweb app lets you display weather conditions on the screen and access various platform features. Later on, you can also add your device to Apple Home.

Wi-Fi connection with Sinopé

1

Tap the thermostat screen to begin.

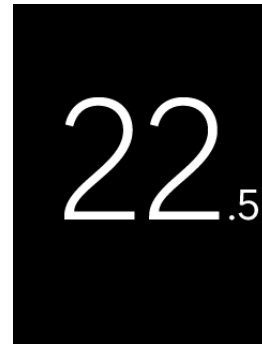

2

Tap the **Settings** icon (⚙️) to access the thermostat settings.

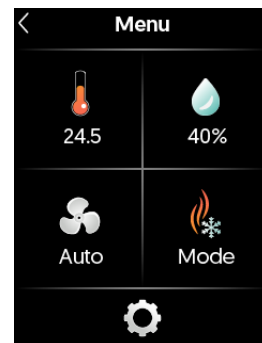

3

In the **Settings** menu, select **Wi-Fi connection**.

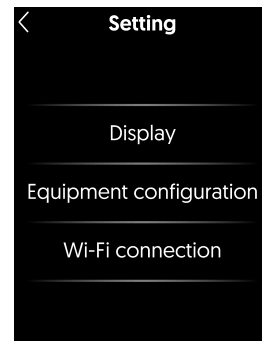

4

Select Sinopé as the configuration platform.

By choosing the **Sinopé Neviweb app**, you will be able to:

- Configure all your thermostat settings from your smartphone
- Display weather information directly on the thermostat screen
- Access advanced features within the Neviweb platform

You can also add your device to **Apple Home** later, if desired.

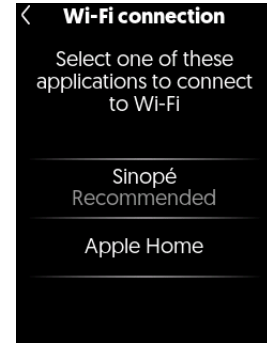

5

Follow the on-screen instructions to complete the Wi-Fi connection.

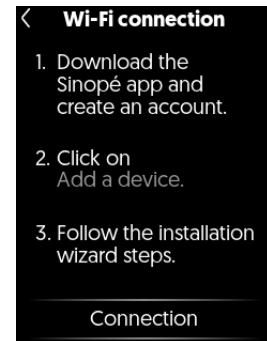

6

Once the Wi-Fi connection is complete, **tap the thermostat tile** in the Sinopé Neviweb app.

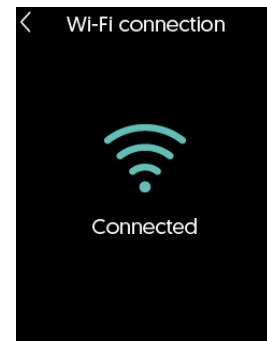

7

Configuring Settings in the App

In the app, tap the Settings icon (⚙️) to access the device settings.

Continue configuring your system by adjusting your preferences in the various menus.



Association with Apple Home

If you have already connected your device via Sinopé and now want to add it to Apple Home, please follow the steps below:

1 Tap on the main screen to access the menu.

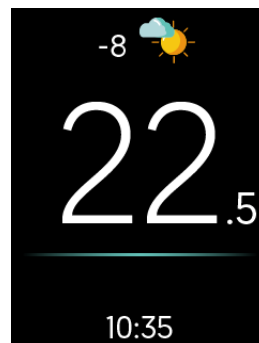

2 Tap the **Settings** icon (⚙️) to access the thermostat settings.

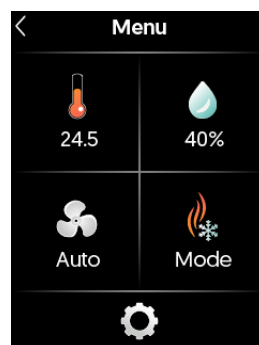

3 In the Settings menu, select **Wi-Fi Connection**.

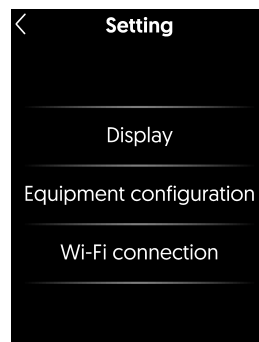

4 Then tap “**Apple Home.**”

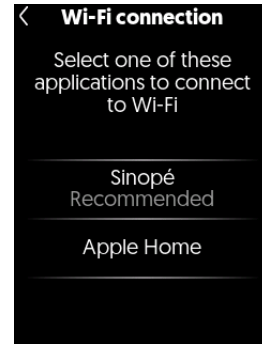

5 Follow the on-screen steps and tap '**Connection.**'

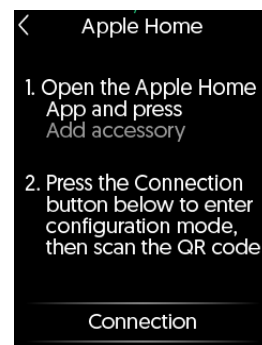

6 Follow the steps displayed on the screen.

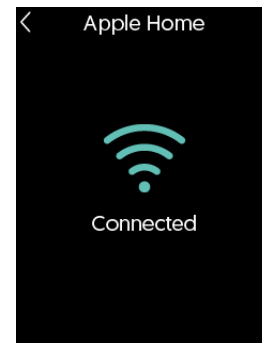
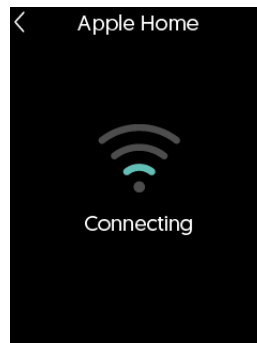

7 Tap the arrow in **the top left corner** to exit the connection menu.



Wi-Fi connection via Apple Home

1 Tap the thermostat screen to begin.

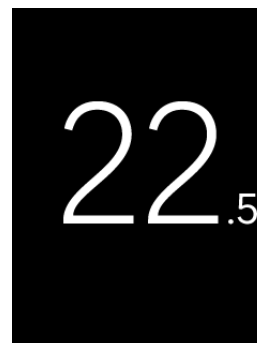

2 Tap the **Settings** icon (⚙️) to access the thermostat settings.

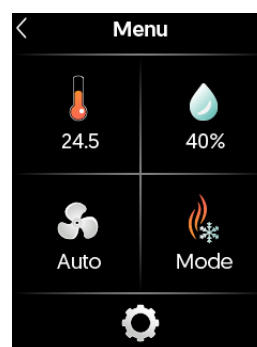

3 In the **Settings** menu, select **Wi-Fi connection**.

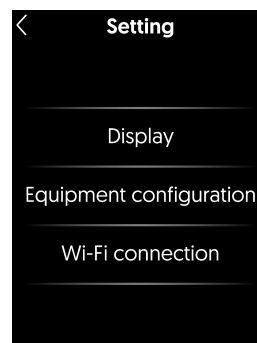

4 Tap 'Apple Home.'

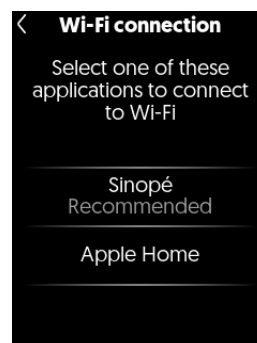

5

Follow the on-screen steps and tap **'Connection'**.

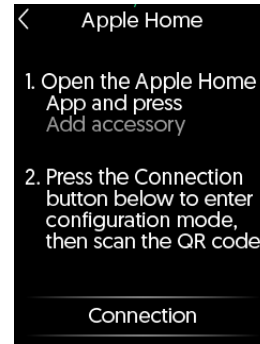

6

Follow the steps displayed on the screen.

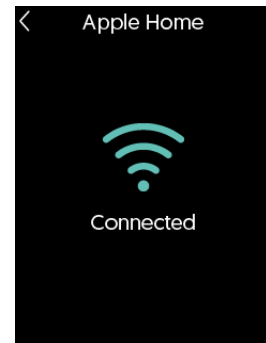

7

We recommend continuing the setup and adding your thermostat to the **Sinopé Neviweb** application.

This platform lets you easily adjust **all thermostat settings** directly from your smartphone.

Additionally, the Sinopé Neviweb app allows you to display weather conditions on the thermostat's screen and access additional features.

Tap **'Get Started'** and follow the on-screen instructions.

Tap the arrow in the top left corner to return to the main page.



Automatic and away-from-home control of this HomeKit-compatible accessory requires a HomePod, Apple TV, or iPad set up as a Home Hub. It is recommended that the software and operating system be updated.

Using the *Works with Apple* badge means that an accessory has been designed to work specifically with the technology identified in the badge and has been certified by the developer to meet Apple's performance standards. Apple is not responsible for the operation of this device or its compliance with safety and regulatory standards.

HomeKit is a trademark of Apple Inc.

Explore more with the Sinopé Neviweb app!

The Sinopé Neviweb application, developed by Sinopé Technologies, a company specializing in smart device design and the largest Canadian manufacturer of such devices for residential and multi-residential sectors, offers comprehensive management of your smart devices.

Sinopé Neviweb is a consumer application for managing various devices, including other thermostats, switches, dimmers, and water damage protection systems.

Discover additional features available in Sinopé for the **smart thermostat**:

- **Set filter replacement reminders:** Ensure the air quality in your home.
- **Adjust screen brightness:** Tailor the screen's responsiveness to your preferences.
- **Screen access control:** Explore different access levels to restrict access for children or in commercial settings.
- **Change the time display format.**
- **Customize setpoints:** Adjust settings based on your schedules and geofencing.
- **View energy consumption graphs.**
- **Add your devices to Éco Sinopé:** Optimize energy use during peak events.

Troubleshooting and support

If you encounter any difficulties during the installation or operation of the thermostat, the Sinopé application, or when connecting to other platforms, we invite you to consult Sinopé's support website by visiting <https://support.sinopetech.com/en/>.

The technical support team will be happy to assist you.

Call us at :

1 (855) 741-7701

Write to us at:

support@sinopetech.com

Find us at :

705 Montrichard Avenue
Saint-Jean-sur-Richelieu
Quebec, Canada (J2X 5K8)

Opening hours :

Monday to Friday - 8:00 am to 4:30 pm (EST)
Saturday & Sunday - Closed

Warranty

3-year Limited Warranty

SINOPÉ TECHNOLOGIES INC. (“Sinopé”) warrants the components of their products against defects in material and workmanship for a 3-year period from the date of purchase, under normal use and service, when proof of purchase of such is provided to the manufacturer. If, at any time during the warranty period, the product is determined to be defective, SINOPÉ TECHNOLOGIES INC. will replace it. This warranty does not cover any transportation costs that may be incurred by the consumer. Nor does it cover a product that has been improperly installed, misused, or accidentally damaged. The obligation of SINOPÉ TECHNOLOGIES INC., under the terms of this warranty, will be to supply a new unit, and this releases the manufacturer from paying the installation costs or other secondary charges linked to replacing the unit or the components. The manufacturer shall not be liable for incidental, consequential, or special damages arising at or in connection with product use or performance. SINOPÉ TECHNOLOGIES INC. is not required to provide replacement parts or repair services after the warranty period expires.

5-Year Extended Pro Warranty

Extended Pro Warranty Terms for Sinopé Pro Products

SINOPÉ TECHNOLOGIES INC. (“Sinopé”) offers an Extended Pro Warranty for select Sinopé Pro products, subject to the following terms and conditions.

1. **Eligibility:** The Extended Pro Warranty applies exclusively to Sinopé Pro products that are (i) sold by authorized Sinopé Pro installers, and (ii) installed by such authorized Sinopé Pro installers, within the United States and Canada. Products purchased or installed through any other channels or by unauthorized parties are not eligible for this warranty extension.
2. **Activation:** The Extended Pro Warranty is automatically activated upon the successful addition of the eligible Sinopé Pro product to the purchaser’s Sinopé account. Activation requires that the product be purchased and installed by an authorized Sinopé Pro installer. If these conditions are not met, the Extended Pro Warranty will not apply.
3. **Standard Warranty:** Sinopé Pro products purchased from channels other than authorized Sinopé Pro installers, or installed by non-authorized parties, are covered only by the standard three (3) year warranty, which commences from the date of purchase.
4. **General Provisions:** This Extended Pro Warranty is subject to the same limitations, exclusions, and conditions as outlined in Sinopé’s standard warranty terms, unless otherwise specified in these terms. All other terms and conditions not expressly modified herein shall remain in full force and effect.

By purchasing and installing Sinopé Pro products through authorized channels, you agree to the terms and conditions outlined in this Extended Pro Warranty.

Technical information

TH6500WF

Smart Wi-Fi thermostat for central system

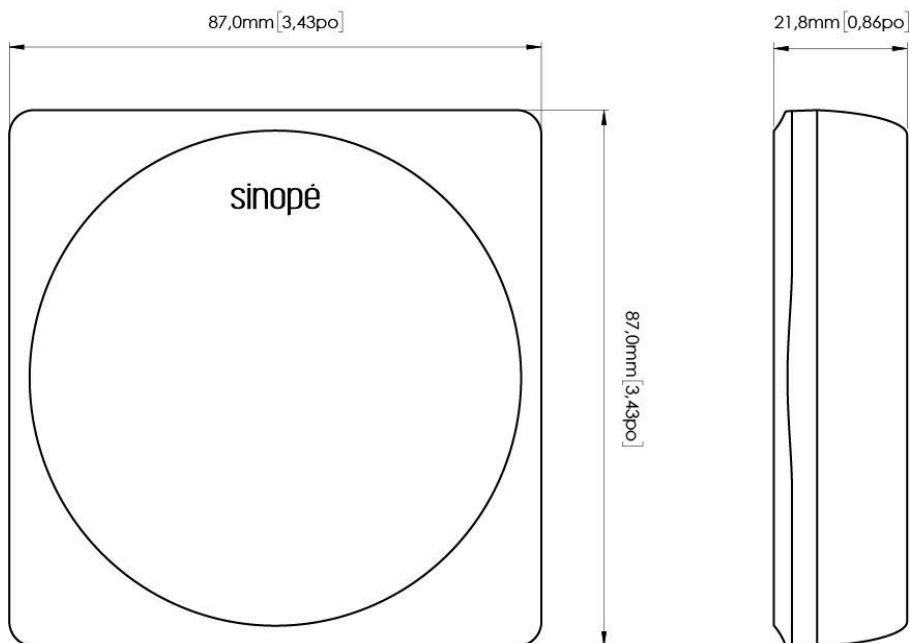

Connectors	See the information on the mounting plate
Power supply	24 VAC
Screen	2.4" color TFT touchscreen 240 px × 320 px
Dimensions(W x H x D)	87 mm (3.43 in) × 87 mm (3.43 in) × 21.8 mm (0.86 in)
Operating temperature	0 °C to 50 °C (32 °F to 122 °F)
Storage temperature	-20 °C to 50 °C (-4 °F to 122 °F)
Sensors	Humidity sensor Proximity sensor Light sensor for adaptive display
Communication protocol	Protocol: Wi-Fi Standard: IEEE 802.11 b/g/n Frequency: 2.4 GHz Encryption key: WPA2
Communication module	IC: 21098-ESPC6WROOM1 FCC ID: 2AC7Z-ESPC6WROOM1
Warranty	Basic - 3 years Pro - 5 years

Mounting plate - TH6500WF

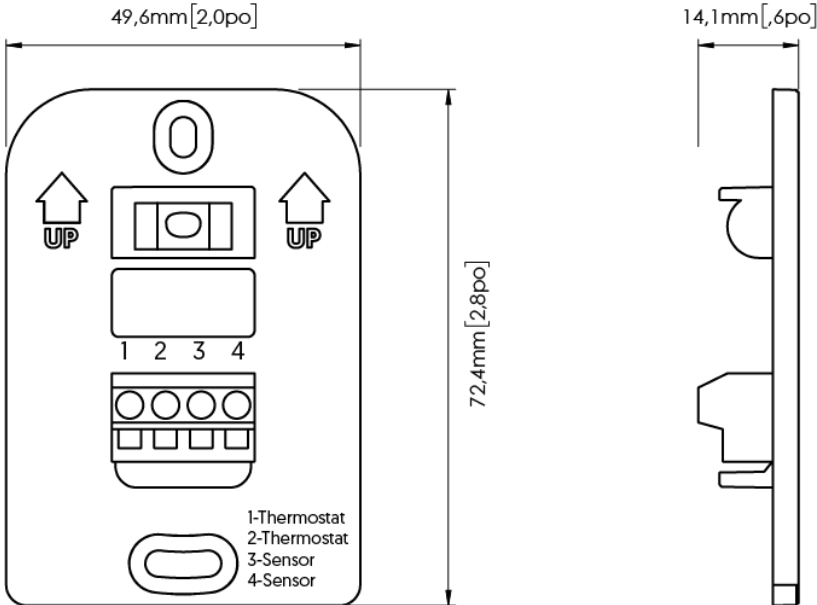

Dimensions (W x H x D)

49.6 mm (1.95 in) × 72.4 mm (2.85 in) × 14.1 mm (0.55 in)

Connectors

4 connectors
 Wire range (Solid): 18-22 AWG
 Wire range (Stranded): 18-22 AWG

Connectors 1 and 2: Thermostat power supply

Connectors 3 and 4: Optional temperature sensor⁷

⁷ These connectors are not yet supported in the current version of the thermostat software. Their support is planned for an upcoming update.

Mounting plate - TH6500WF Rev: 01

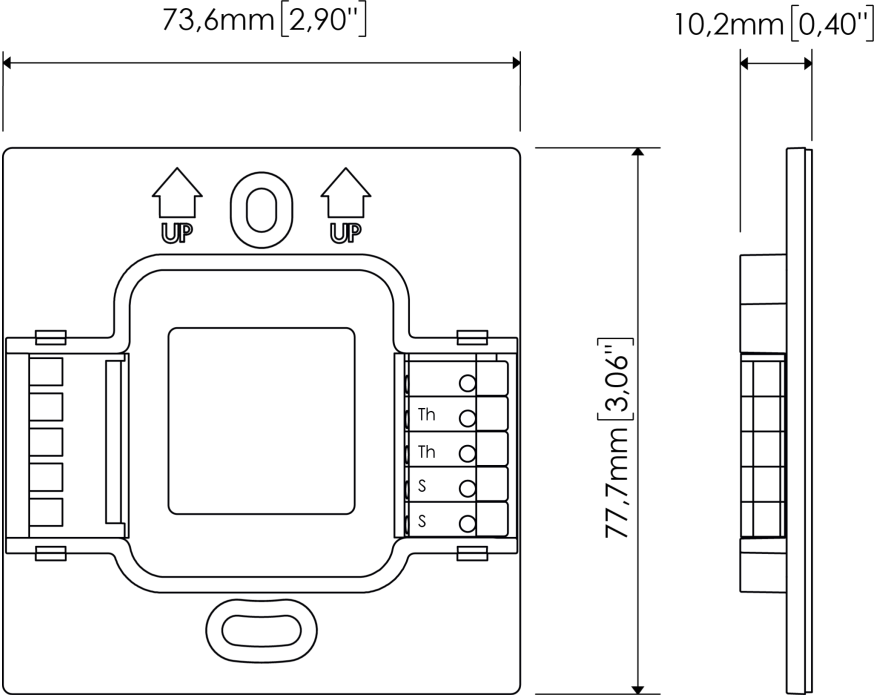

Dimensions (W x H x D) 73.6 mm (2.90 in) x 77.7 mm (3.06 in) x 10.2 mm (0.40 in)

Connectors 4 connectors
 Wire range (Solid): 18-22 AWG
 Wire range (Stranded): 18-22 AWG

“Th” connectors: Thermostat power supply

“S” connectors: Optional temperature sensor⁸

⁸ These connectors are not yet supported in the current version of the thermostat software. Their support is planned for an upcoming update.

TB6500

Central system connection module

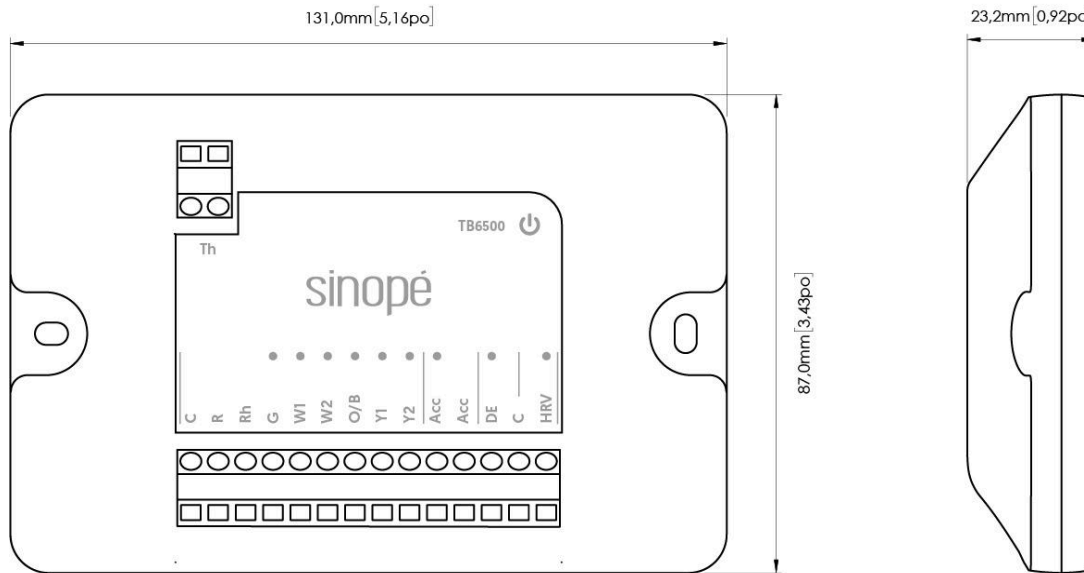

Connectors	Wire range: 18-24 AWG
Power supply	RC from heat pump / HVAC (24 Vac)
Current per output	0.5A, total 2A Current for one output used (G, Y1, Y2, W1, W2, O/B): Minimum: 0.0025 A. Maximum: 0.5 A. Total current for all outputs used (G, Y1, Y2, W1, W2, O/B): 2 A. Acc output: independent, accepts between 0 and 2 A at 24 Vac. HRV and DE inputs: designed for dry contacts, but tolerate resistance up to 10 kΩ.
Dimensions (W x H x D)	131 mm (5.16 in) × 87 mm (3.43 in) × 23.2 mm (0.92 in)
Operating temperature	0 °C to 50 °C (32 °F to 122 °F)
Storage temperature	-20 °C to 50 °C (-4 °F to 122 °F)
Warranty	Basic - 3 years Pro - 5 years

Controlling this HomeKit-enabled accessory automatically and away from home requires a HomePod, Apple TV, or iPad set up as a home hub. It is recommended that you update to the latest software and operating system. Use of the Works with Apple badge means that an accessory has been designed to work specifically with the technology identified in the badge and has been certified by the developer to meet Apple performance standards. Apple is not responsible for the operation of this device or its compliance with safety and regulatory standards. HomeKit is a trademark of Apple Inc.

Sinopé® is a registered trademark of Sinopé Technologies Inc. in Canada and the United States.

Apple and the Apple logo are trademarks of Apple Inc., registered in the U.S. and other countries. App Store is a service mark of Apple Inc., registered in the U.S. and other countries.

Google Play and the Google Play logo are trademarks of Google Inc.

The Wi-Fi CERTIFIED™ Logo is a certification mark of Wi-Fi Alliance®.

ISED Canada compliance statement

This device contains licence-exempt transmitter(s)/receiver(s) that comply with Innovation, Science and Economic Development Canada's licence-exempt RSS(s). Operation is subject to the following two conditions:

- This device may not cause interference.
- This device must accept any interference, including interference that may cause undesired operation of the device.

FCC compliance statement

This equipment has been tested and found to comply with the limits for a Class B digital device, pursuant to part 15 of the FCC Rules. These limits are designed to provide reasonable protection against harmful interference in a residential installation.

This equipment generates, uses and can radiate radio frequency energy, and if not installed and used in accordance with the instructions, may cause harmful interference to radio communications. However, there is no guarantee that interference will not occur in a particular installation.

If this equipment does cause harmful interference to radio or television reception, which can be determined by turning the equipment OFF and ON, the user is encouraged to try to correct the interference by one or more of the following measures:

- Reorient or relocate the receiving antenna.
- Increase the separation between the equipment and receiver.
- Connect the equipment into an outlet on a circuit different from that to which the receiver is connected.
- Consult the dealer or an experienced radio/TV technician for help.

Wiring diagrams

Conventional system

Wiring 1: 1H

This system refers to a **single-stage heating system without ventilation**. Standard connection for furnaces.

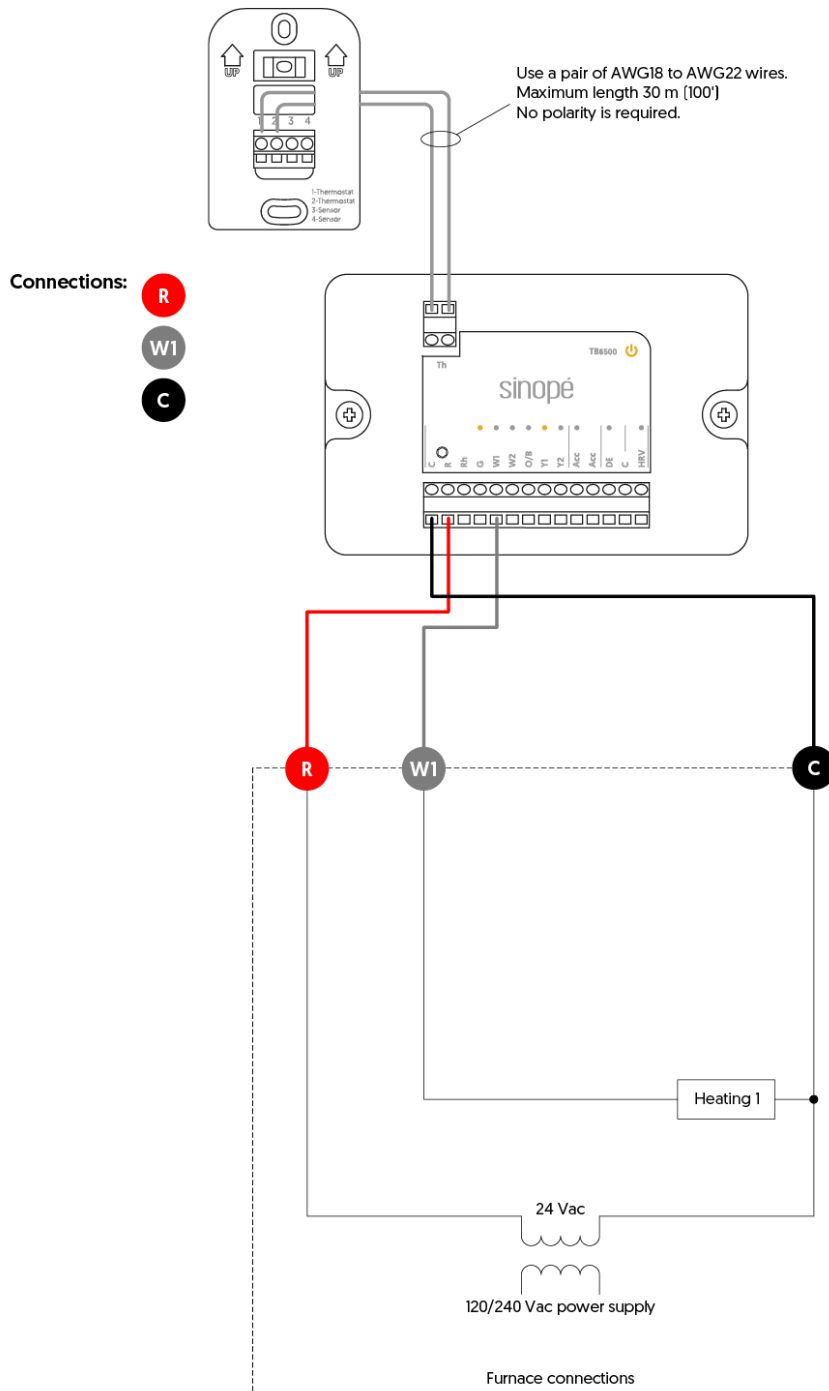

Wiring 2: 1H

This system refers to a **single-stage heating system with ventilation control**. Standard connection for furnaces.

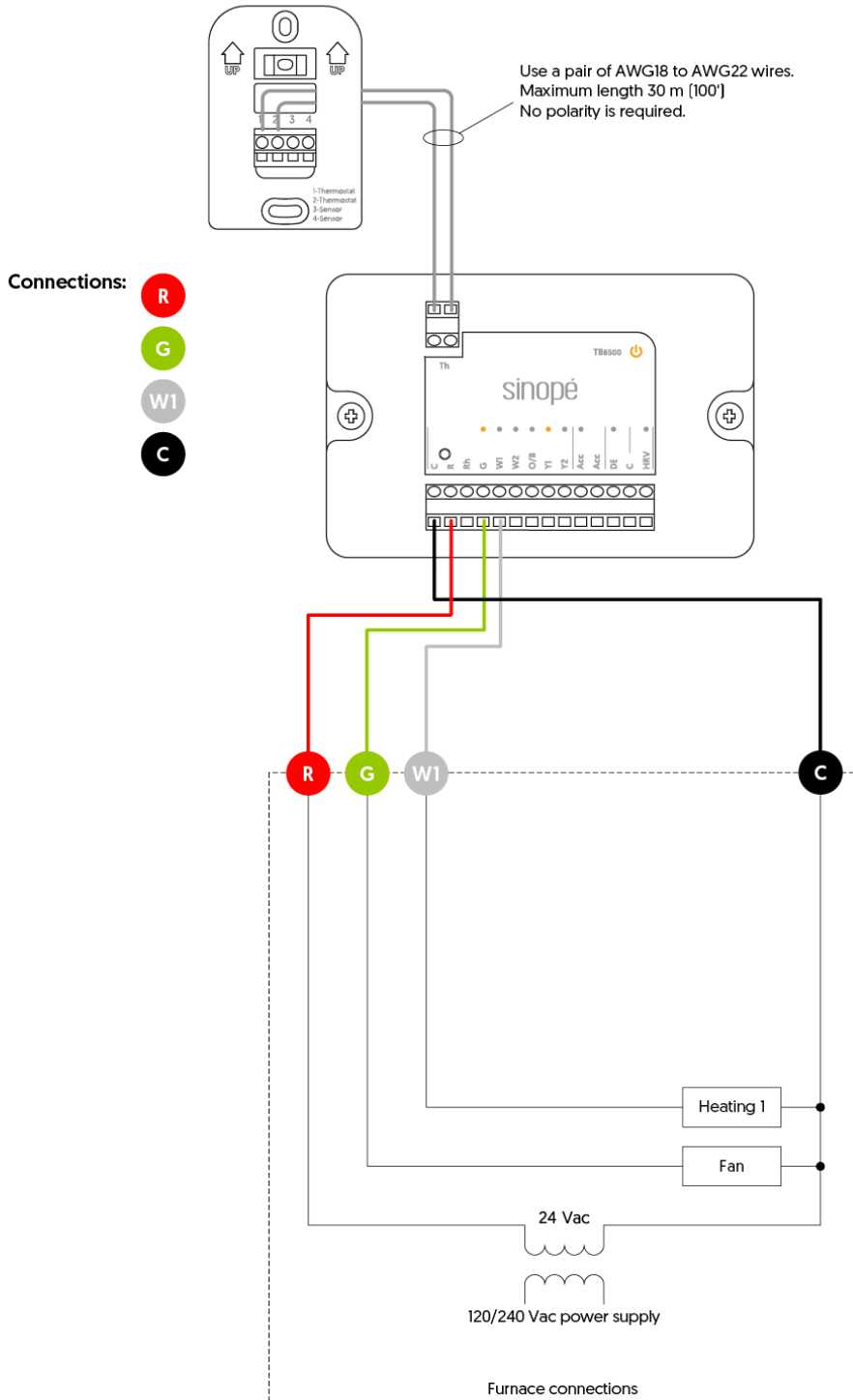

Wiring 3: 2H

This system refers to a heating and ventilation system designed to handle **two stages of heating**. Standard connection for furnaces.

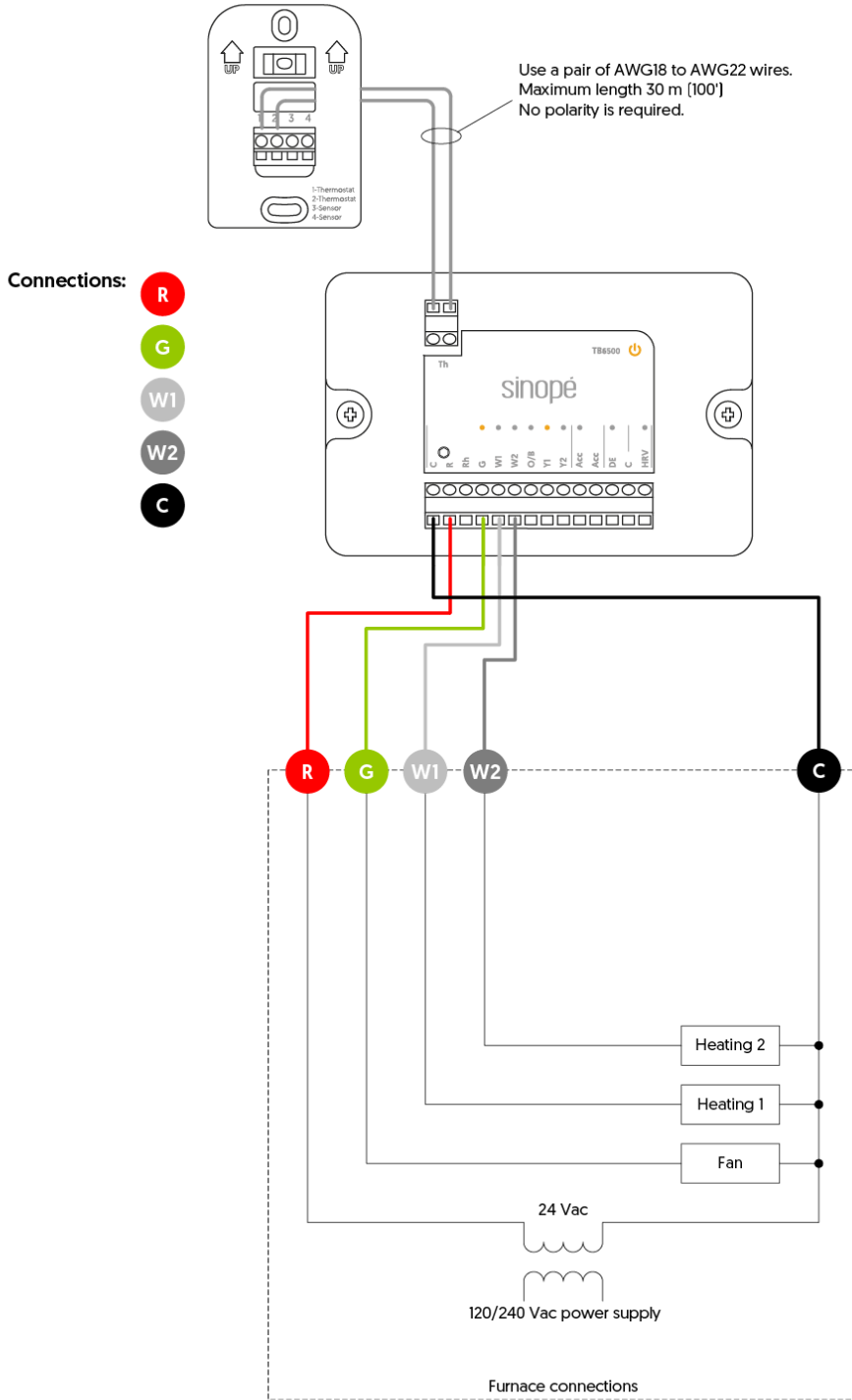

Wiring 4: 1C

This system refers to a **single-stage air conditioning system with ventilation control**. Standard connection for air conditioners.

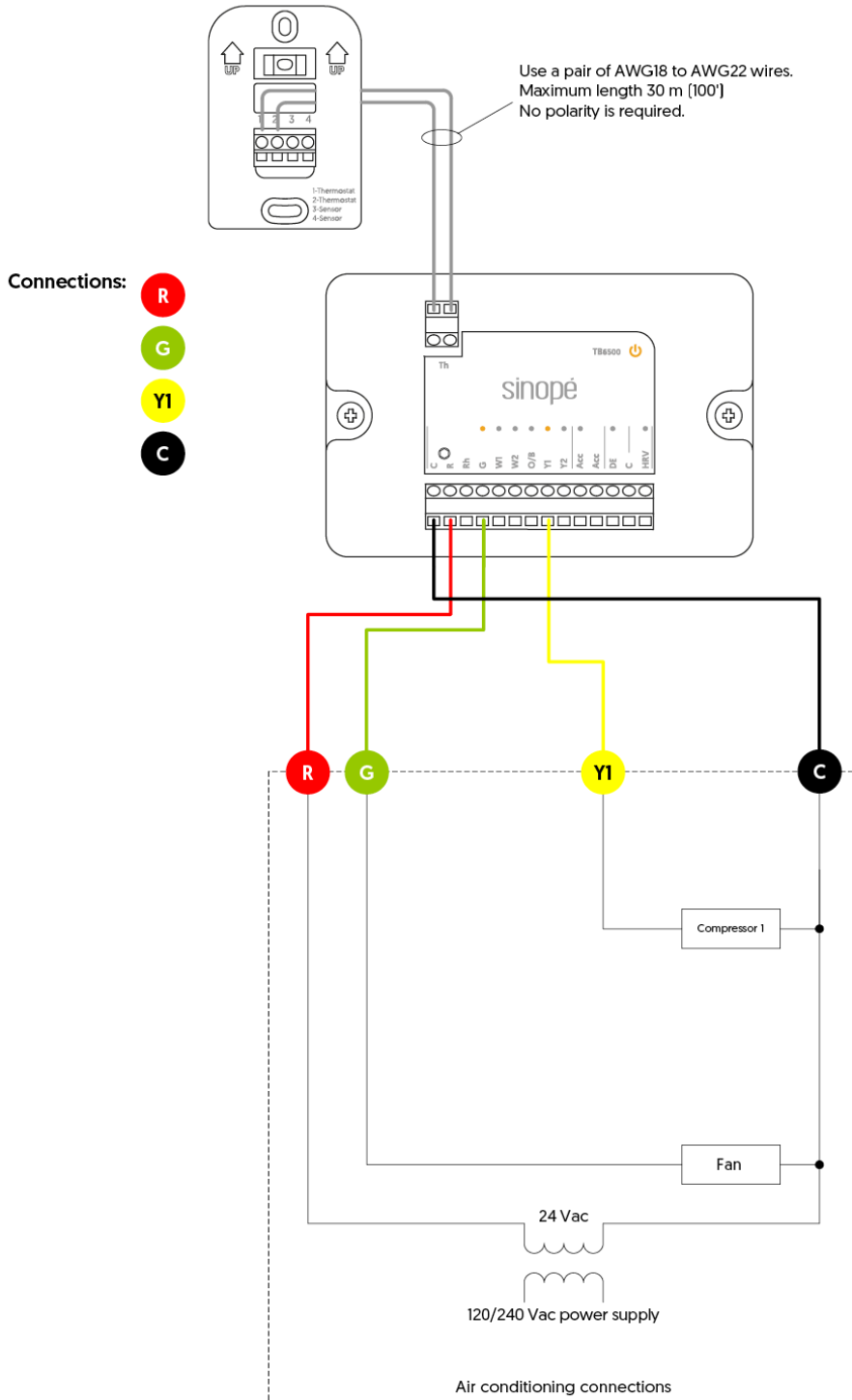

Wiring 5: 2C

This system refers to an air conditioning and ventilation system designed to handle **two stages of air conditioning**. Standard connection for air conditioners.

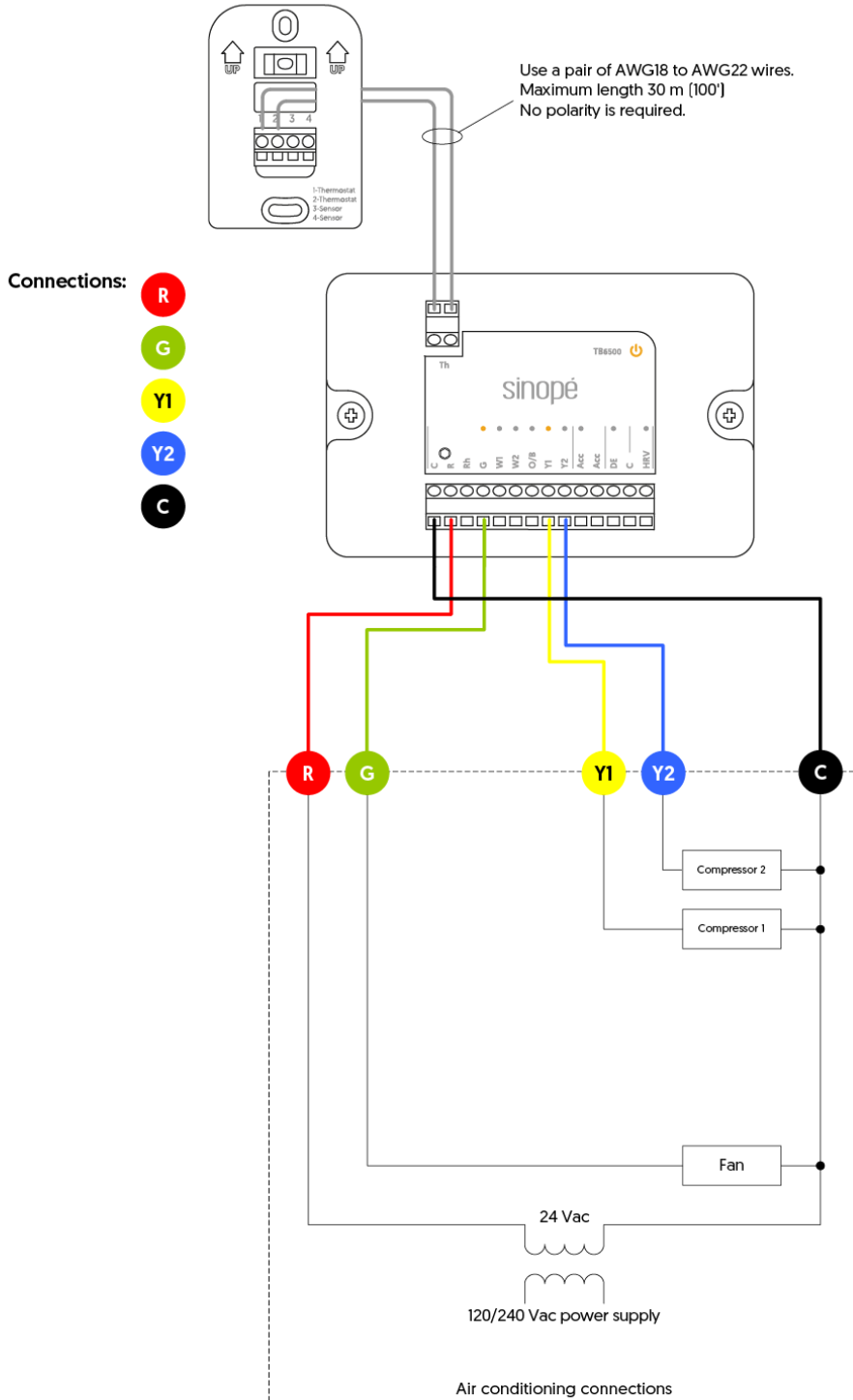

Wiring 6: 1H1C

This system refers to a heating, ventilation, and air conditioning system designed for **one heating** and **one cooling stage**.

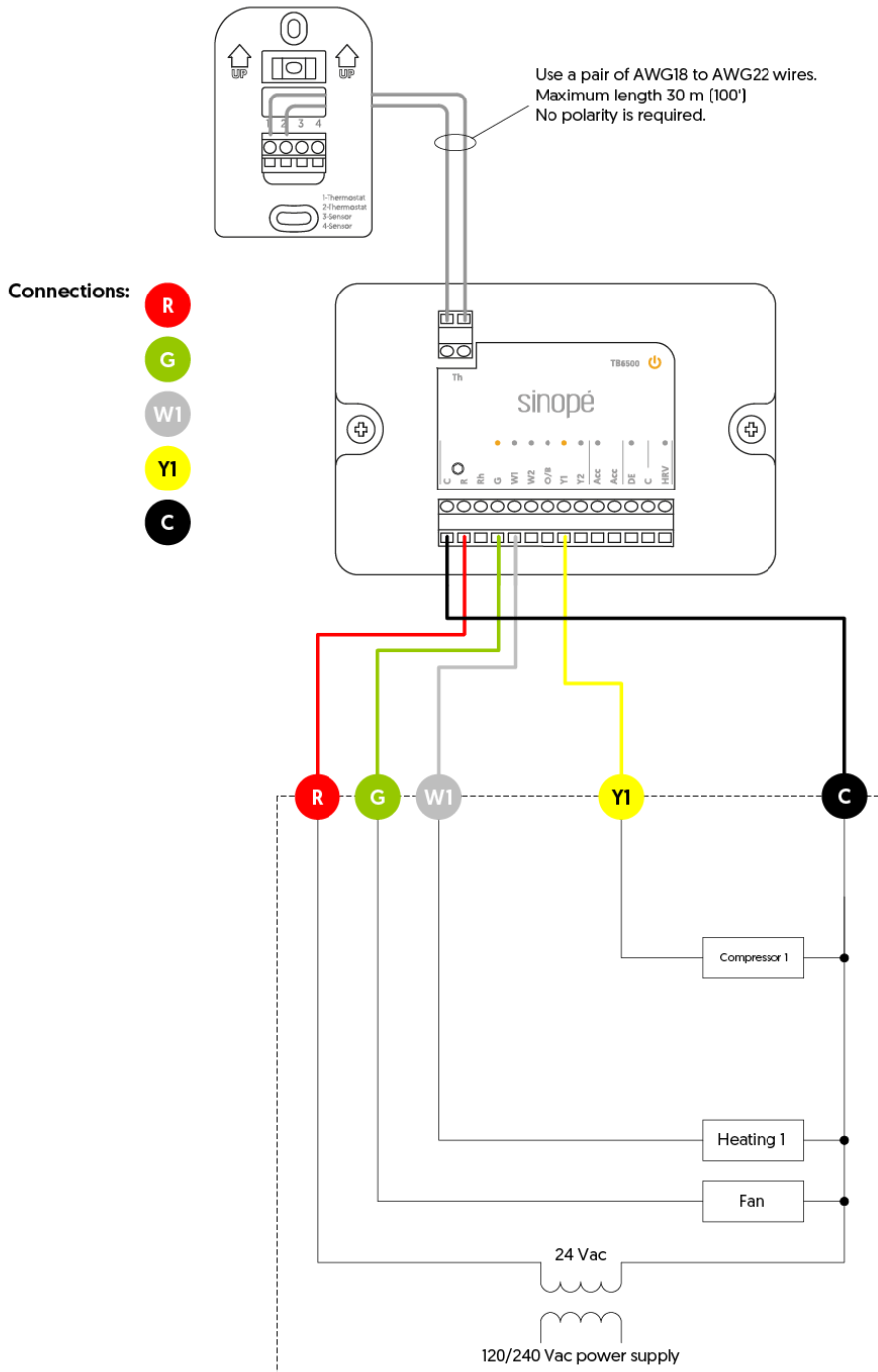

Wiring 7: 1H1C

This system refers to a heating, ventilation, and air conditioning system designed for **one heating and one cooling stage, with separate power for dual-part systems.**

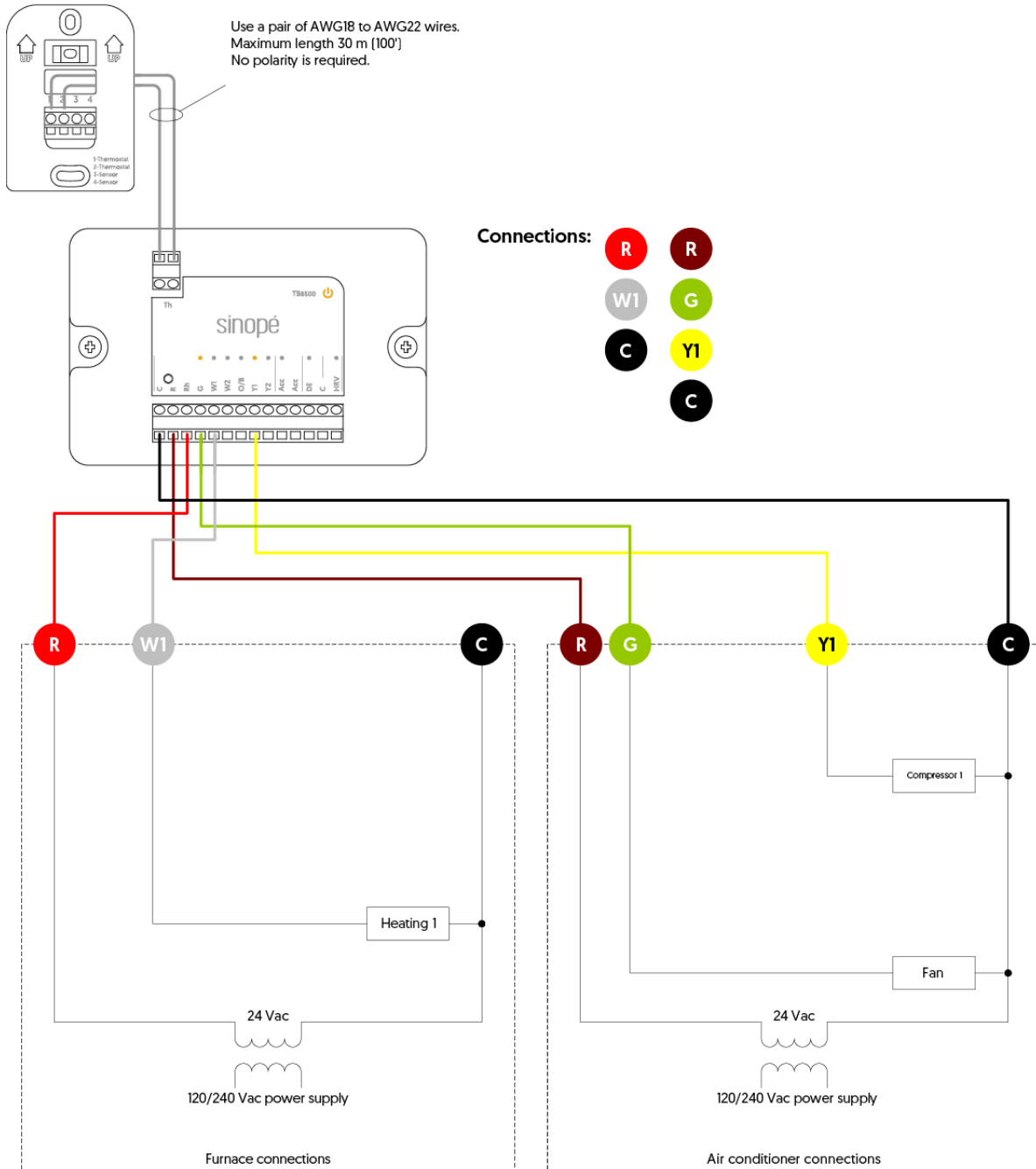

Wiring 8: 1H2C

Refers to an HVAC system with **one heating stage and two air conditioning stages with ventilation control.**

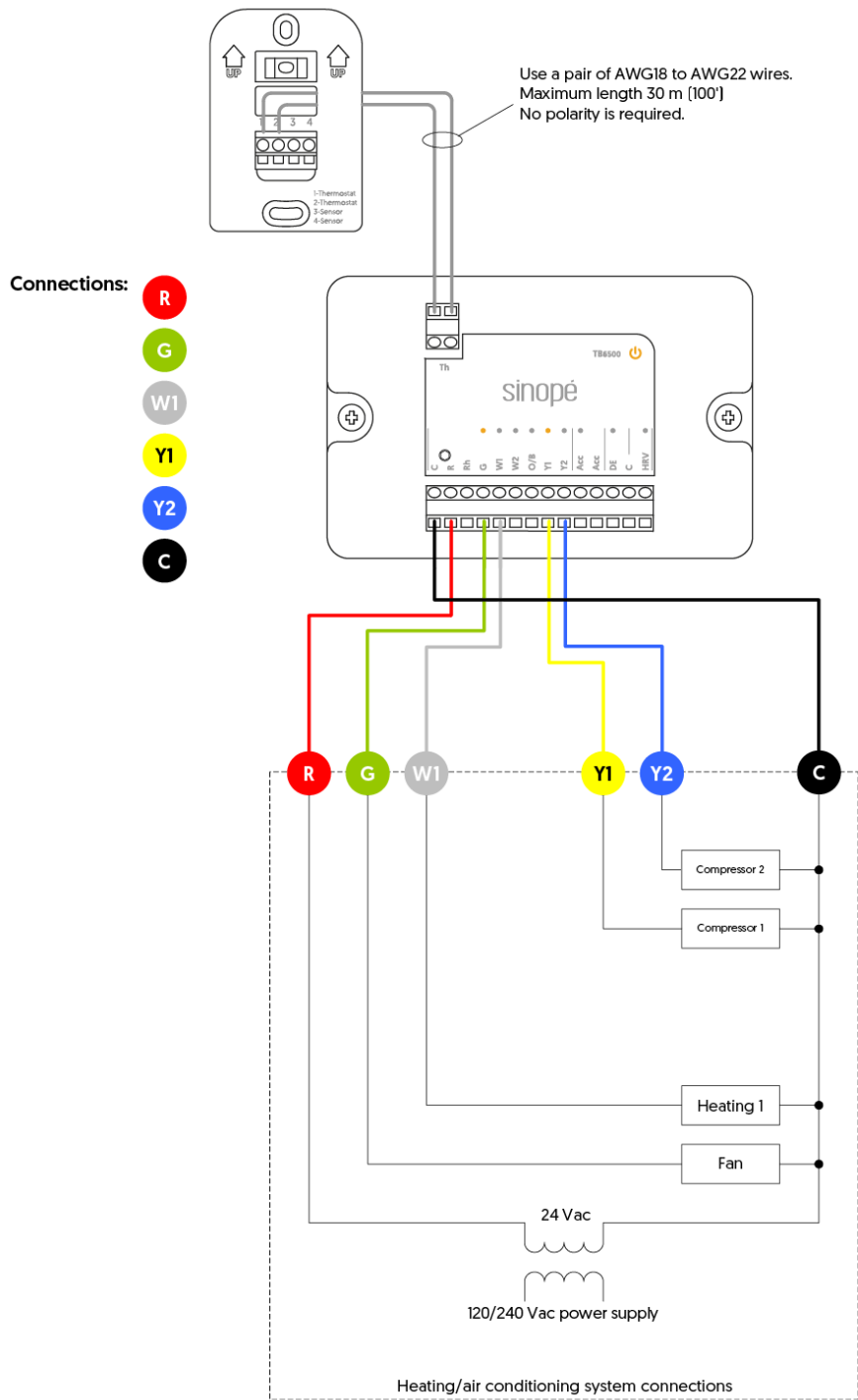

Wiring 9: 1H2C

Refers to an HVAC system with **one heating stage** and **two air conditioning stages** with **ventilation control**. Separate power for heating and cooling. Standard connection for a furnace combined with an air conditioner.

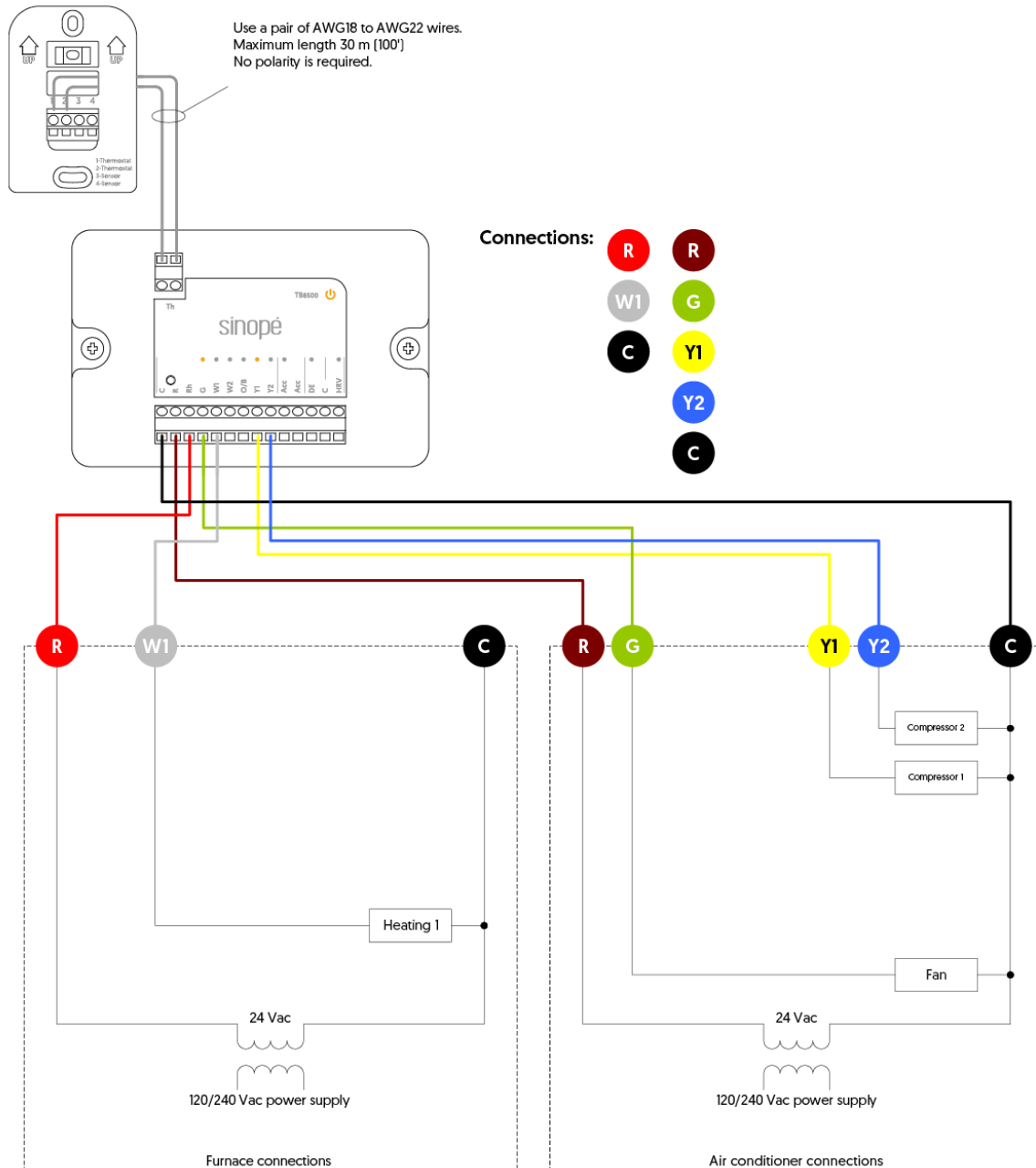

Wiring 10: 2H1C

This system refers to a heating, ventilation, and air conditioning system designed for **two heating** and **one cooling stage**.

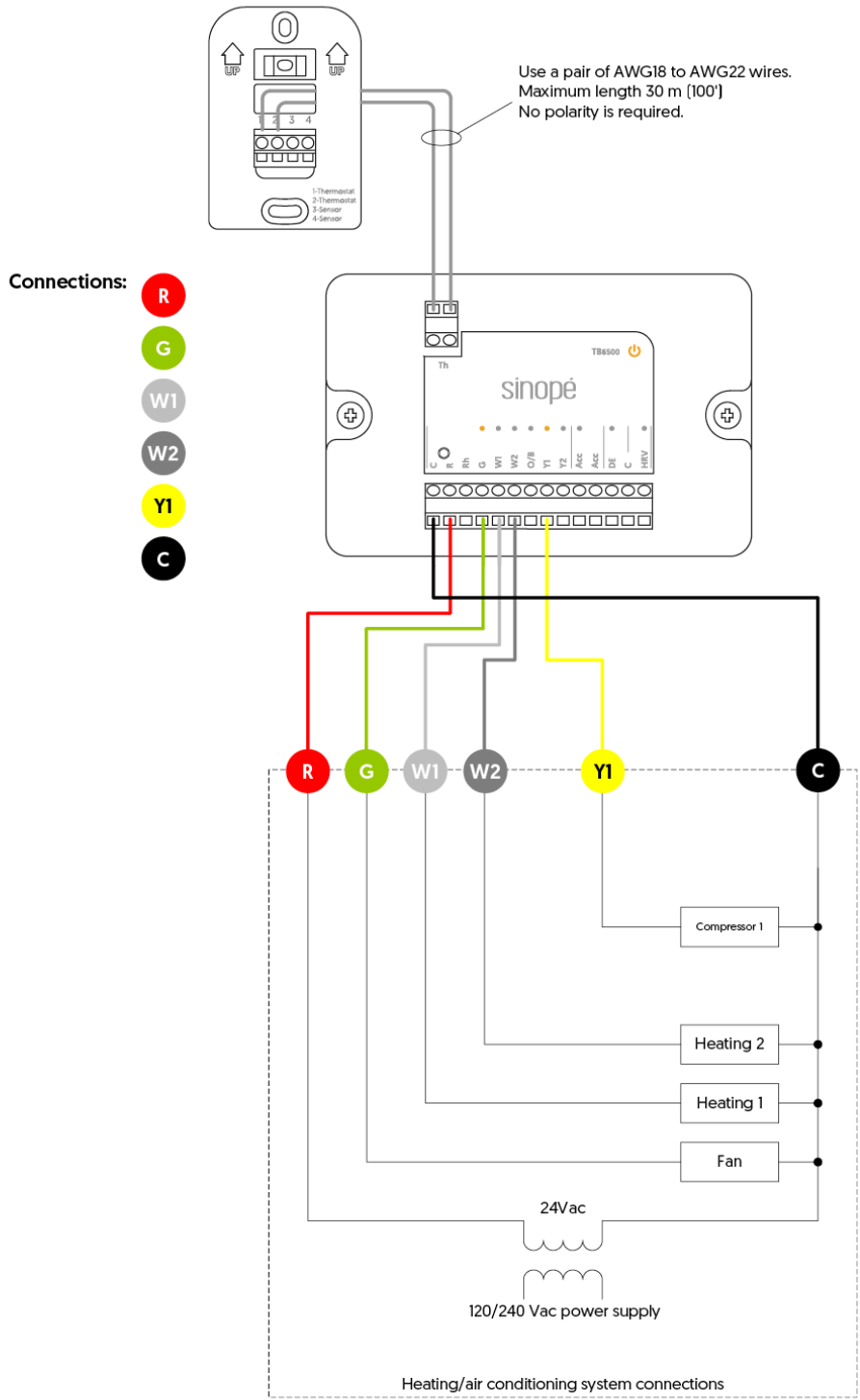

Wiring 11: 2H1C

This system refers to a heating, ventilation, and air conditioning system designed for **two heating** and **one cooling stage, with separate power for dual-part systems.**

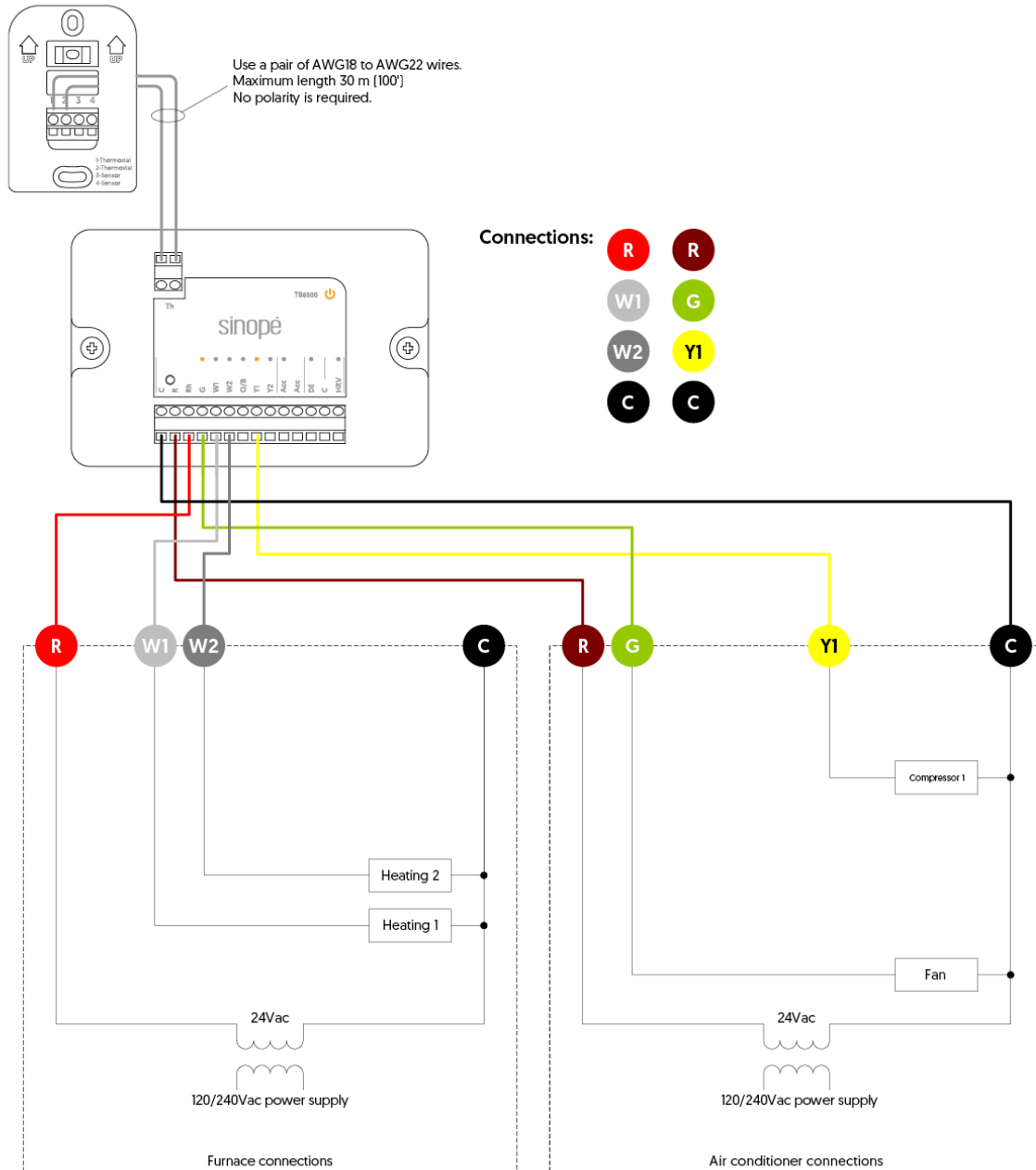

Wiring 12: 2H2C

This system refers to a heating, ventilation, and air conditioning system designed for **two heating** and **two cooling** stages.

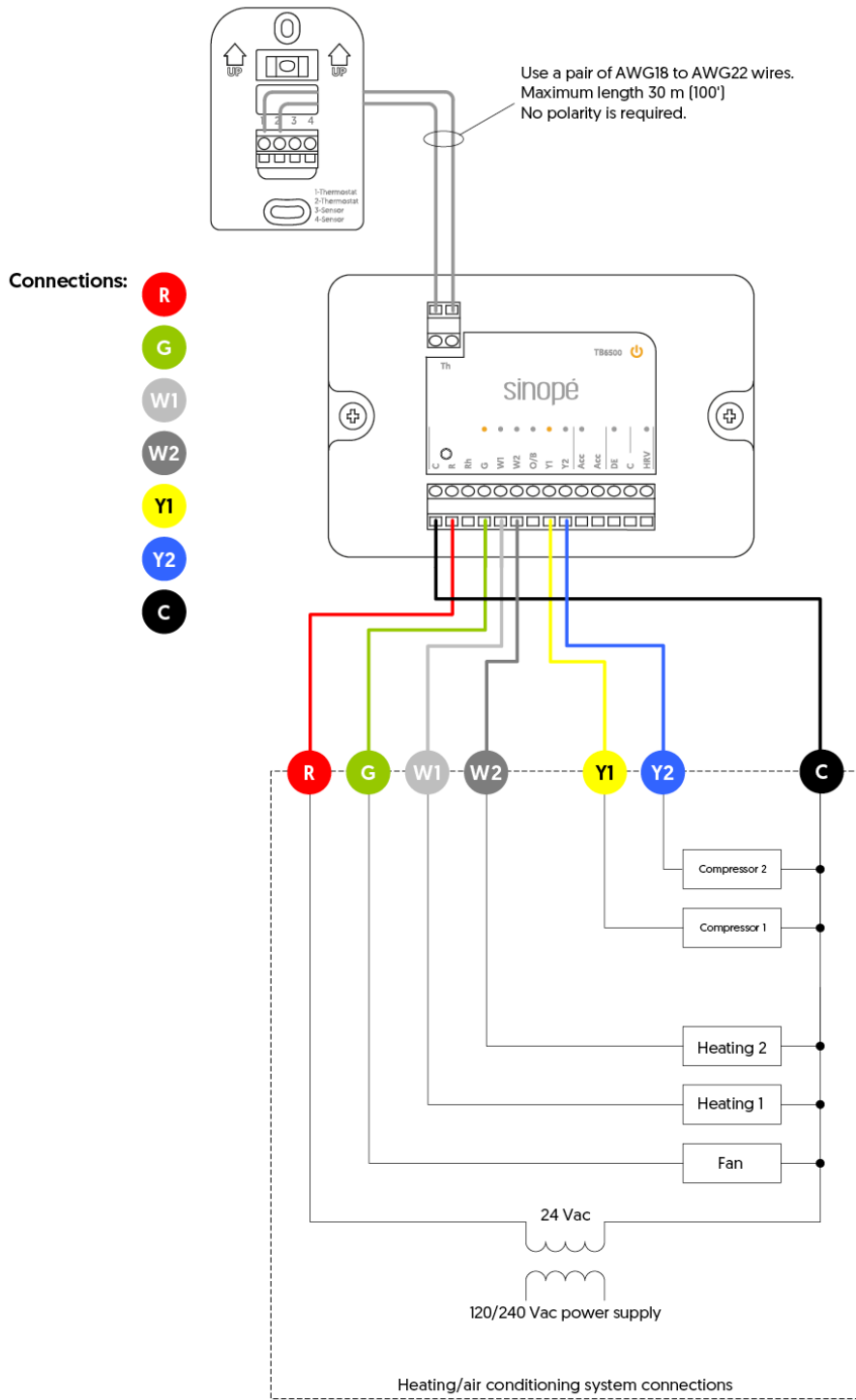

Wiring 13: 2H2C

This system refers to a heating, ventilation, and air conditioning system designed for **two heating** and **two cooling stages**, with **separate power for dual-part systems**.

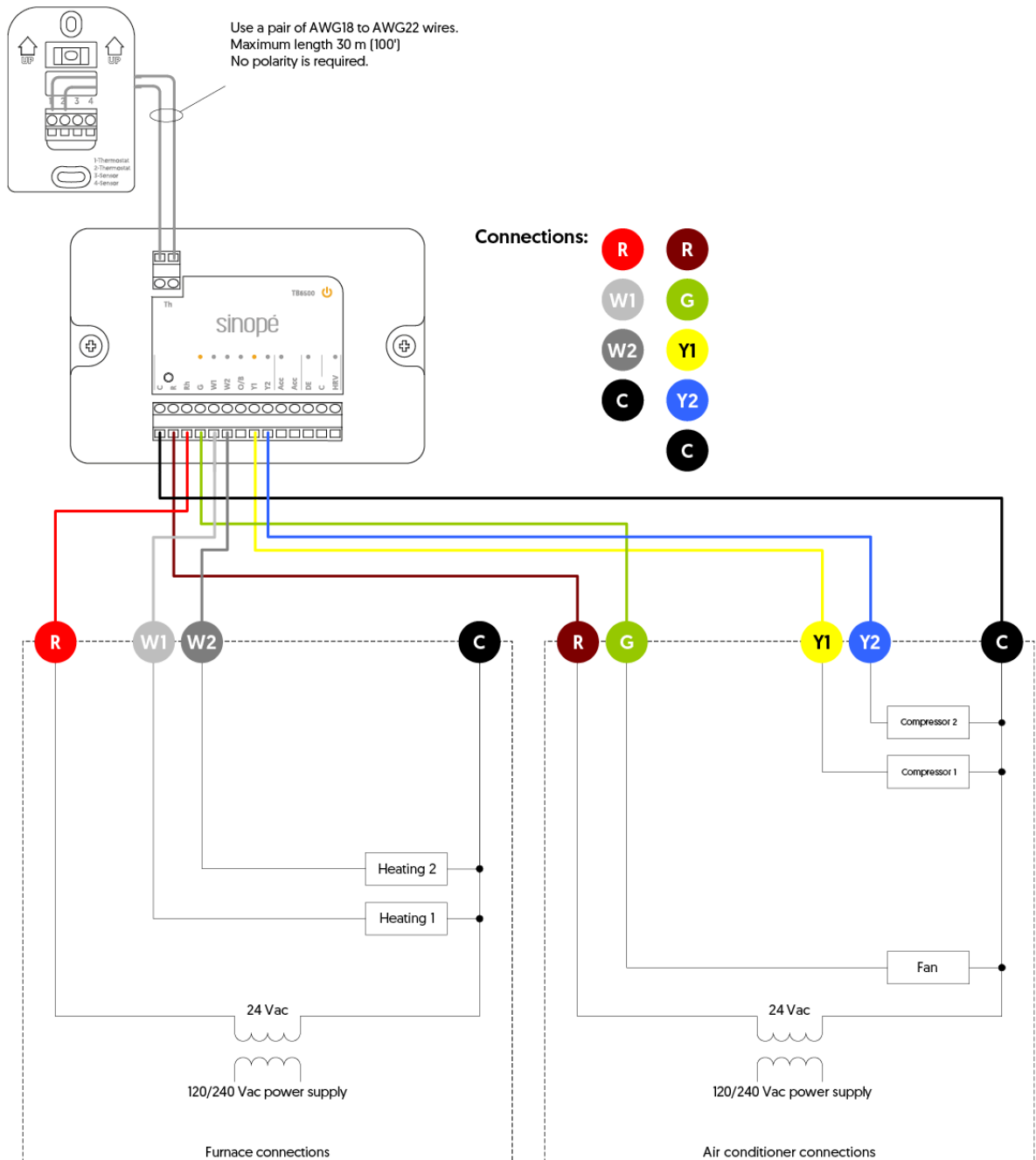

Heat pump

Wiring 14: 1H1C

System to control heating and cooling functions, as well as fan operation, at a **single stage**. Standard connection for heat pumps.

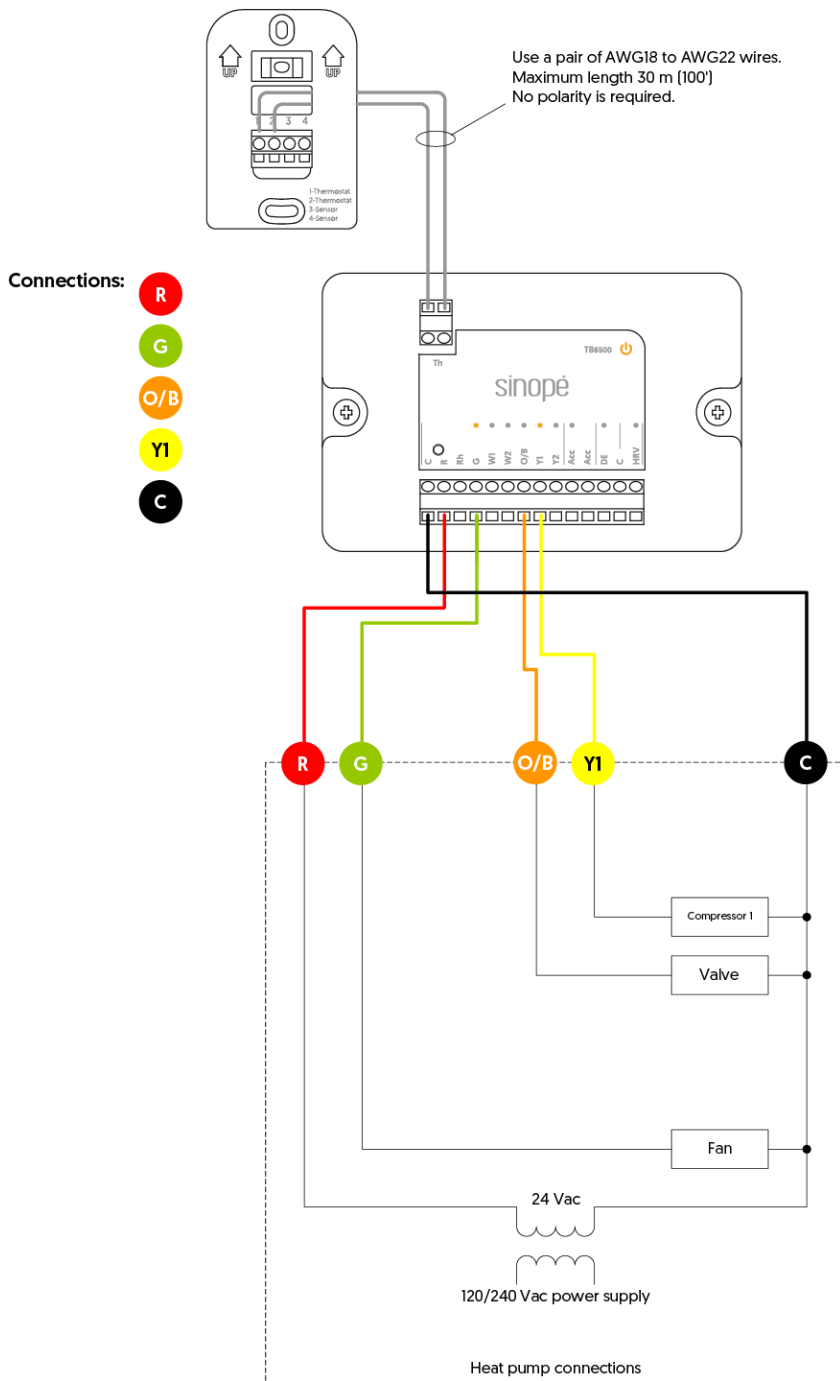

Wiring 15: 2H1C

Refers to an HVAC system with **two heating stages** and **one air conditioning stage** with **ventilation control**. Standard connection for heat pumps.

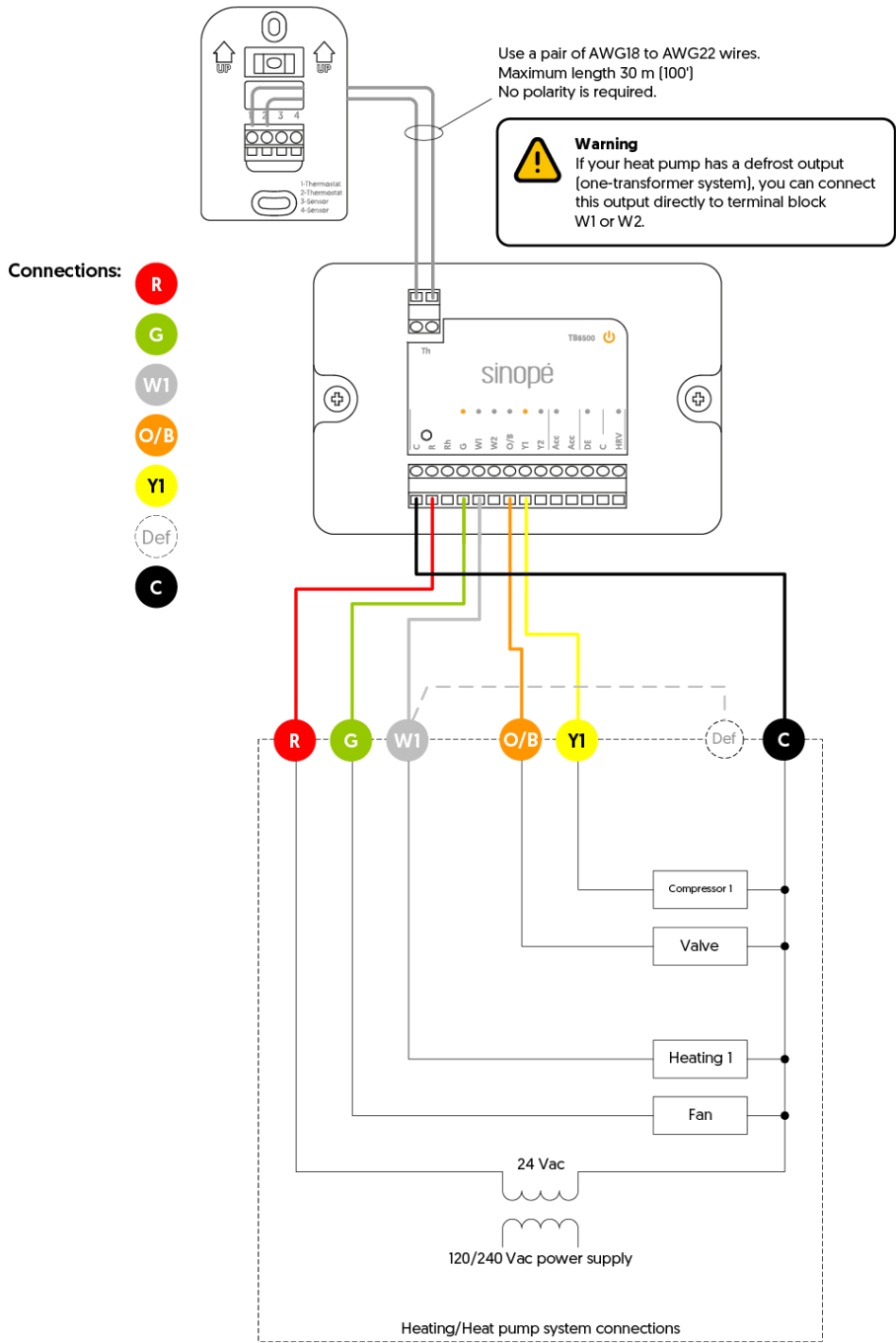

Wiring 16: 2H1C

Refers to an HVAC system with **two heating stages** and **one air conditioning stage** with **ventilation control**. Separate power for heating and cooling. Standard connection for a heat pump combined with a furnace.

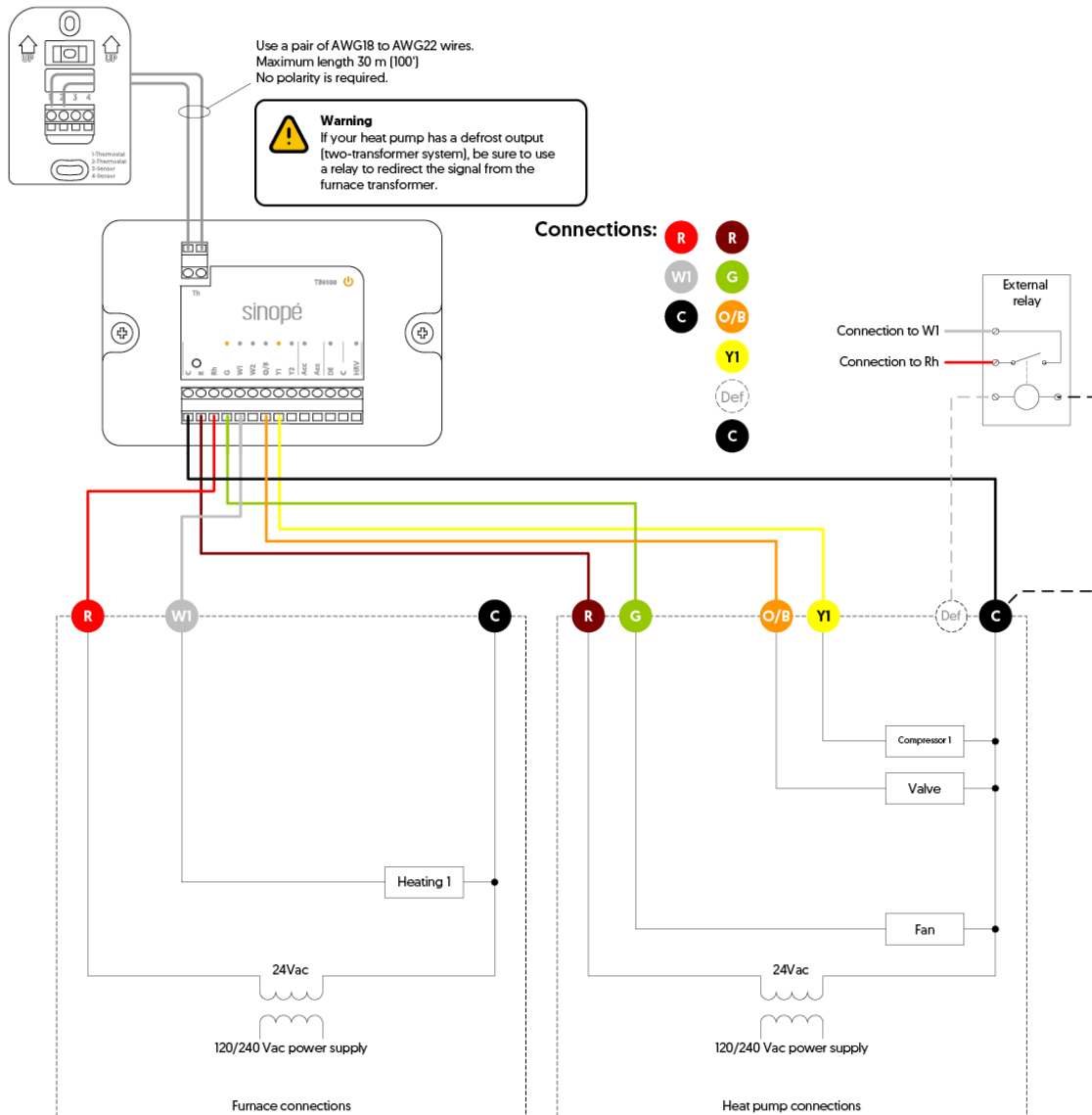

Wiring 17: 2H2C

Refers to an HVAC system with **two heating stages** and **two air conditioning stages** with **ventilation control**.

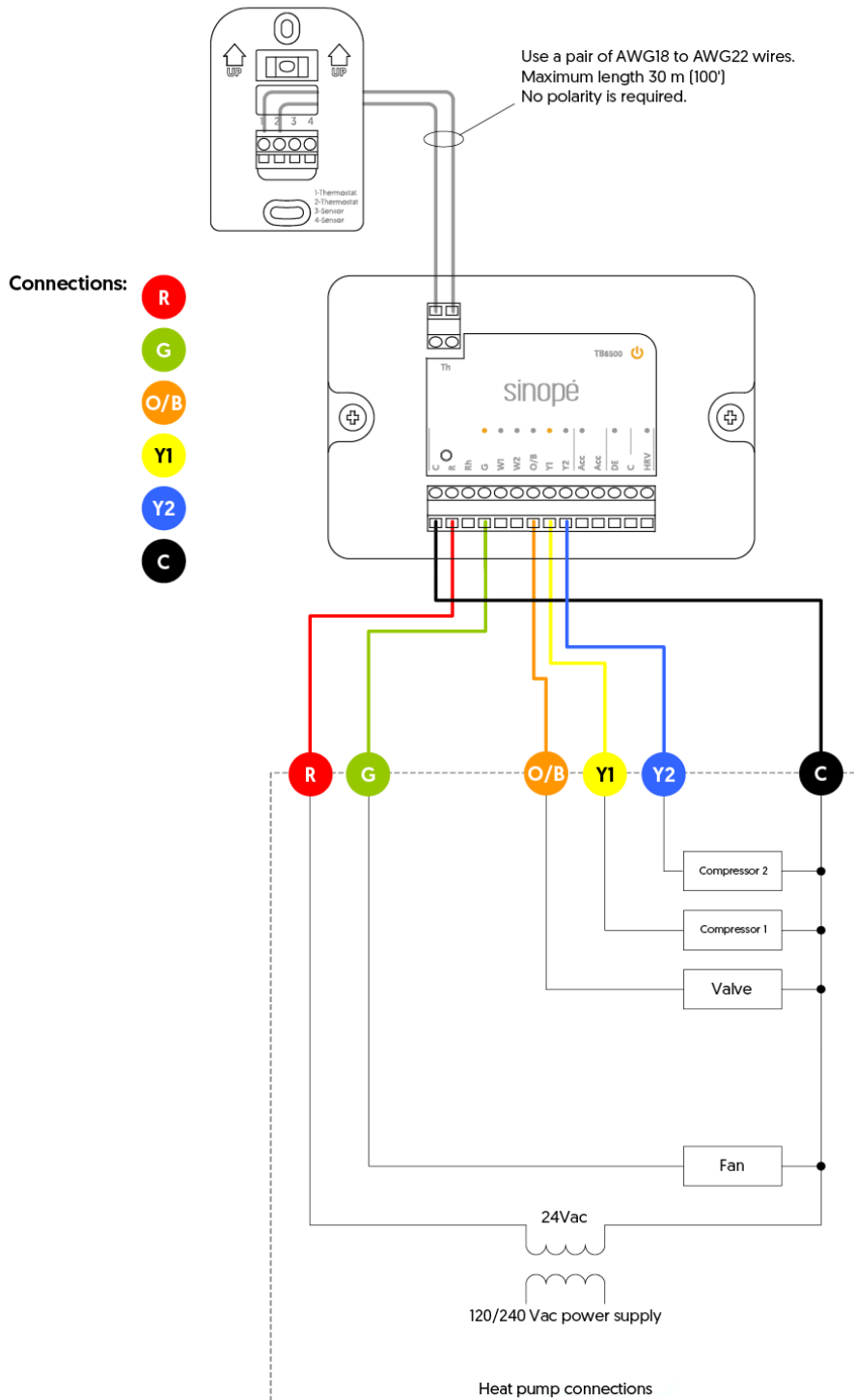

Wiring 18: 3H1C

Refers to an HVAC system with **three heating stages** and **one air conditioning stage** with **ventilation control**. Standard connection for a heat pump with dual-stage auxiliary heating.

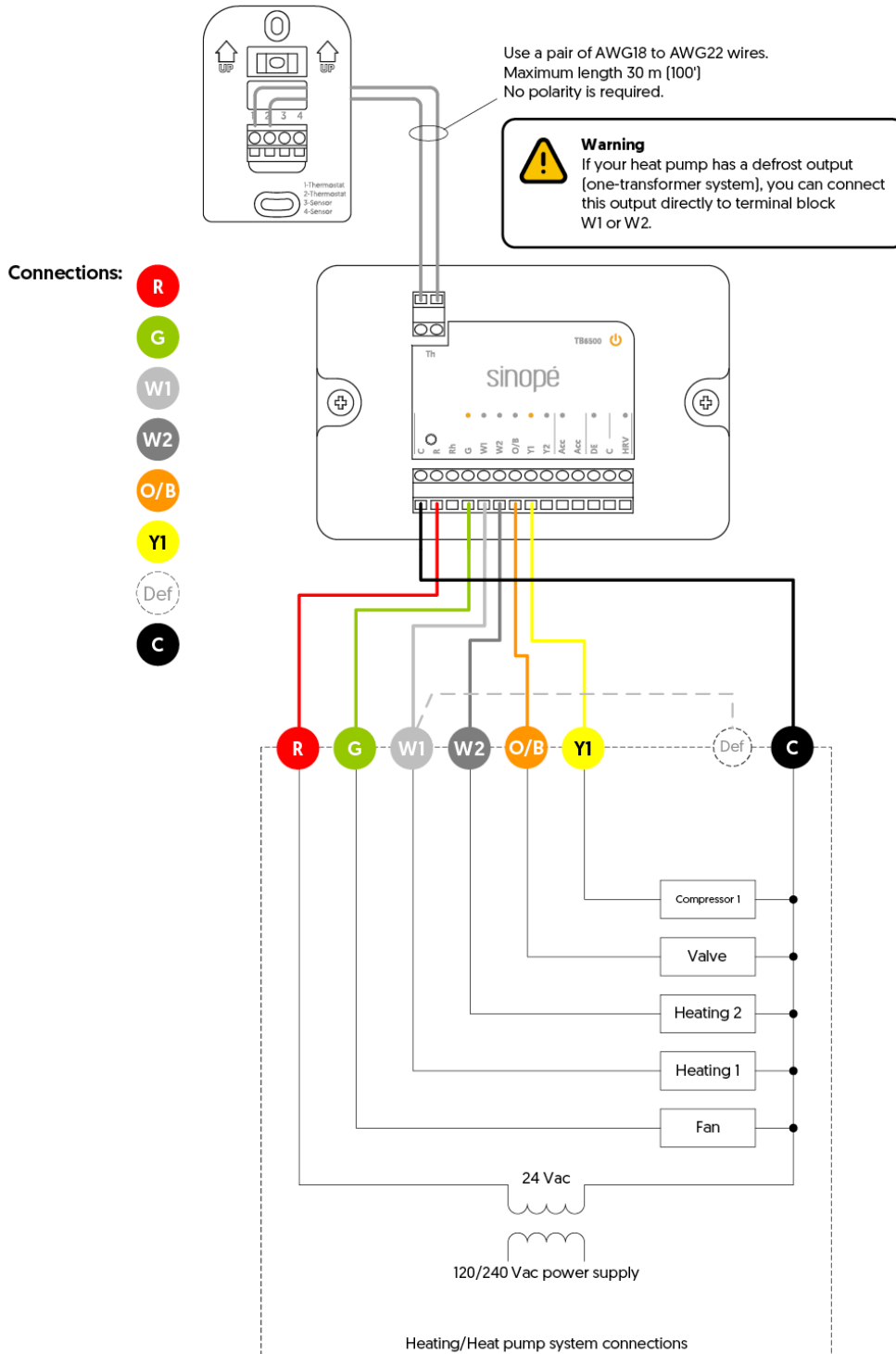

Wiring 19: 3H1C

Refers to an HVAC system with **three heating stages** and **one air conditioning stage** with **ventilation control**. **Separate power for heating and cooling**. Standard connection for a heat pump with dual-stage auxiliary heating.

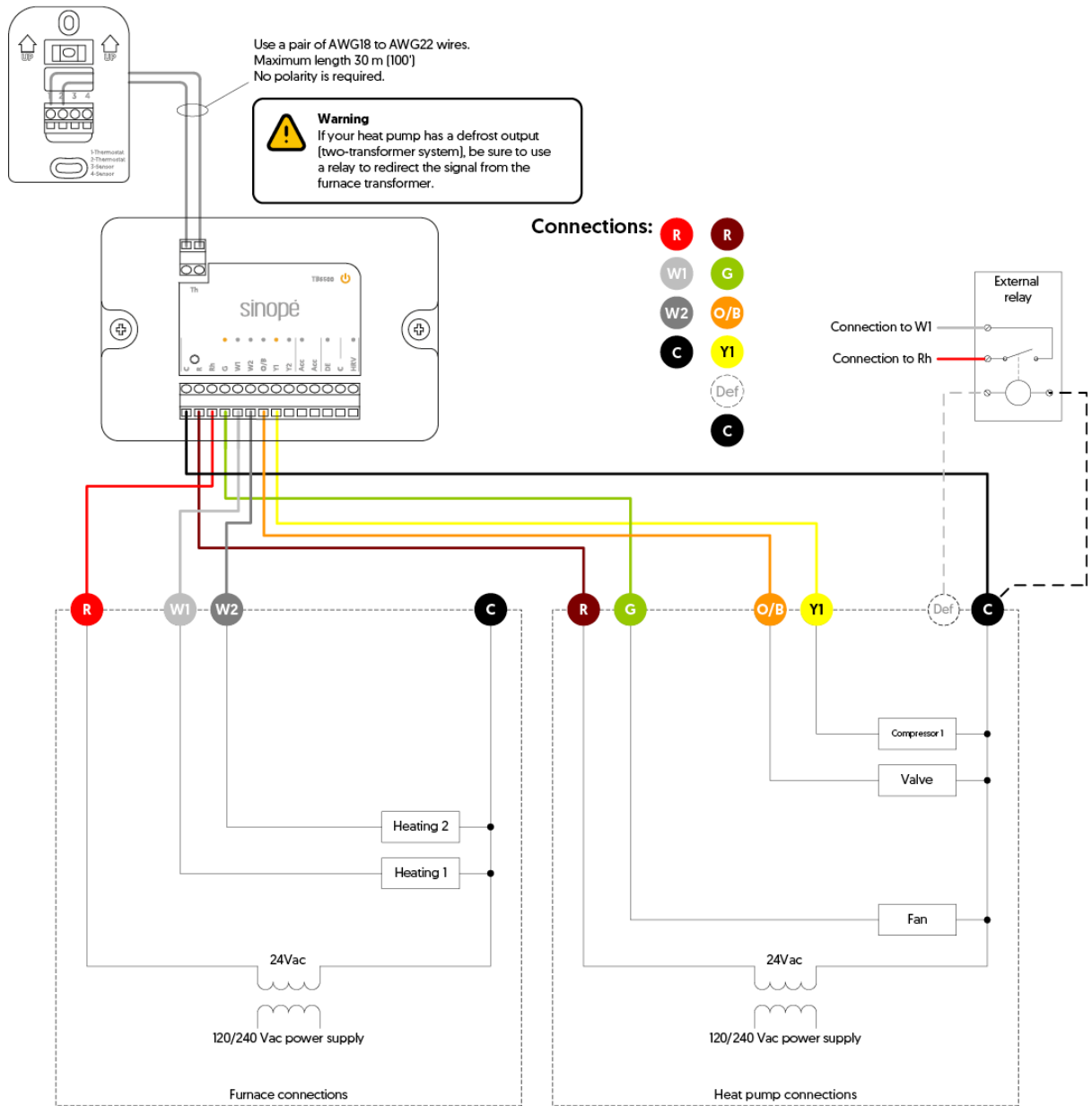

Wiring 20: 3H2C

Refers to an HVAC system with **three heating stages** and **two air conditioning stages** with **ventilation control**. Standard connection for heat pumps.

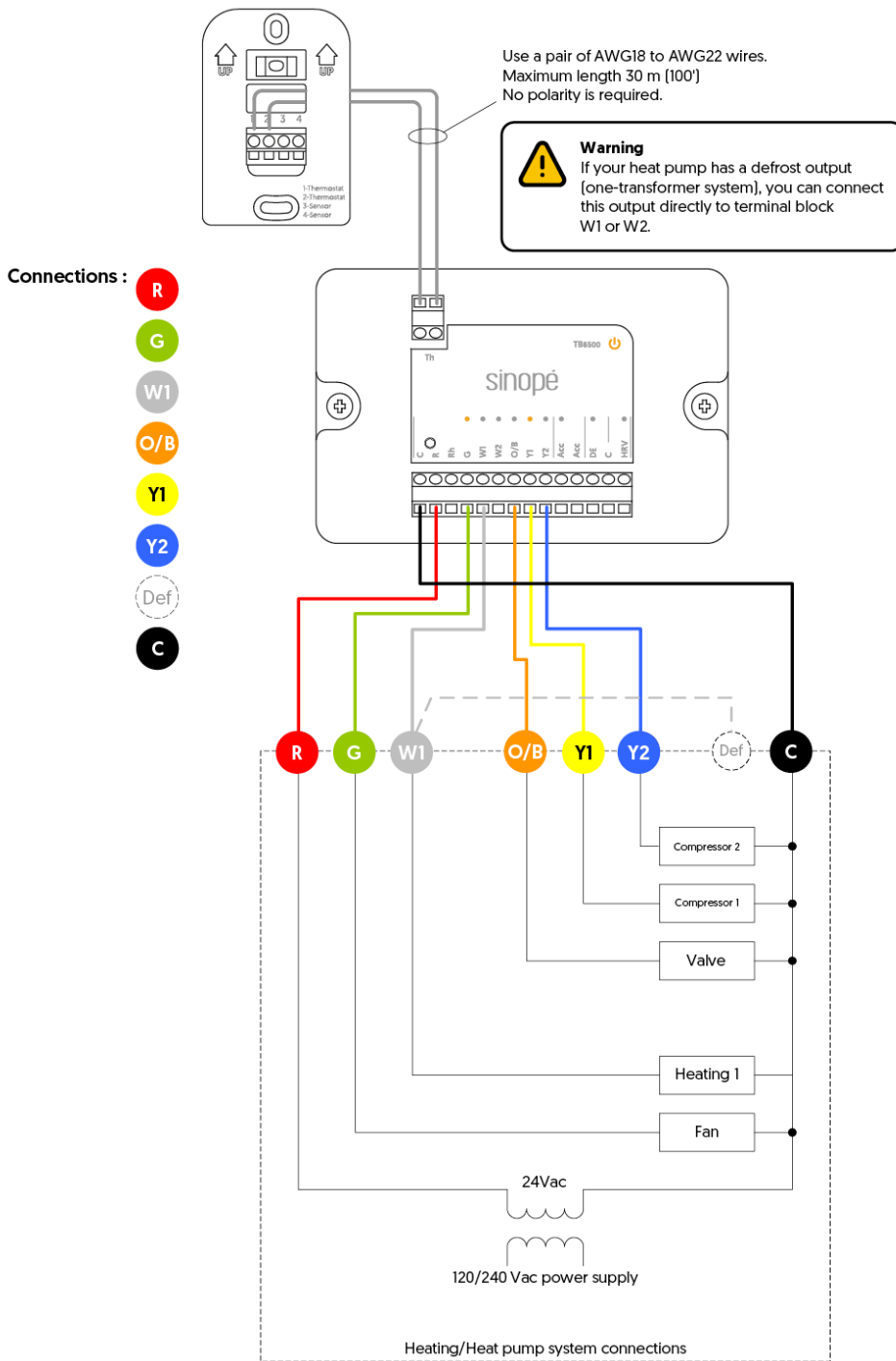

Wiring 21: 3H2C

Refers to an HVAC system with **three heating stages** and **two air conditioning stages** with **ventilation control**. **Separate power for heating and cooling**. Standard connection for a heat pump combined with a furnace.

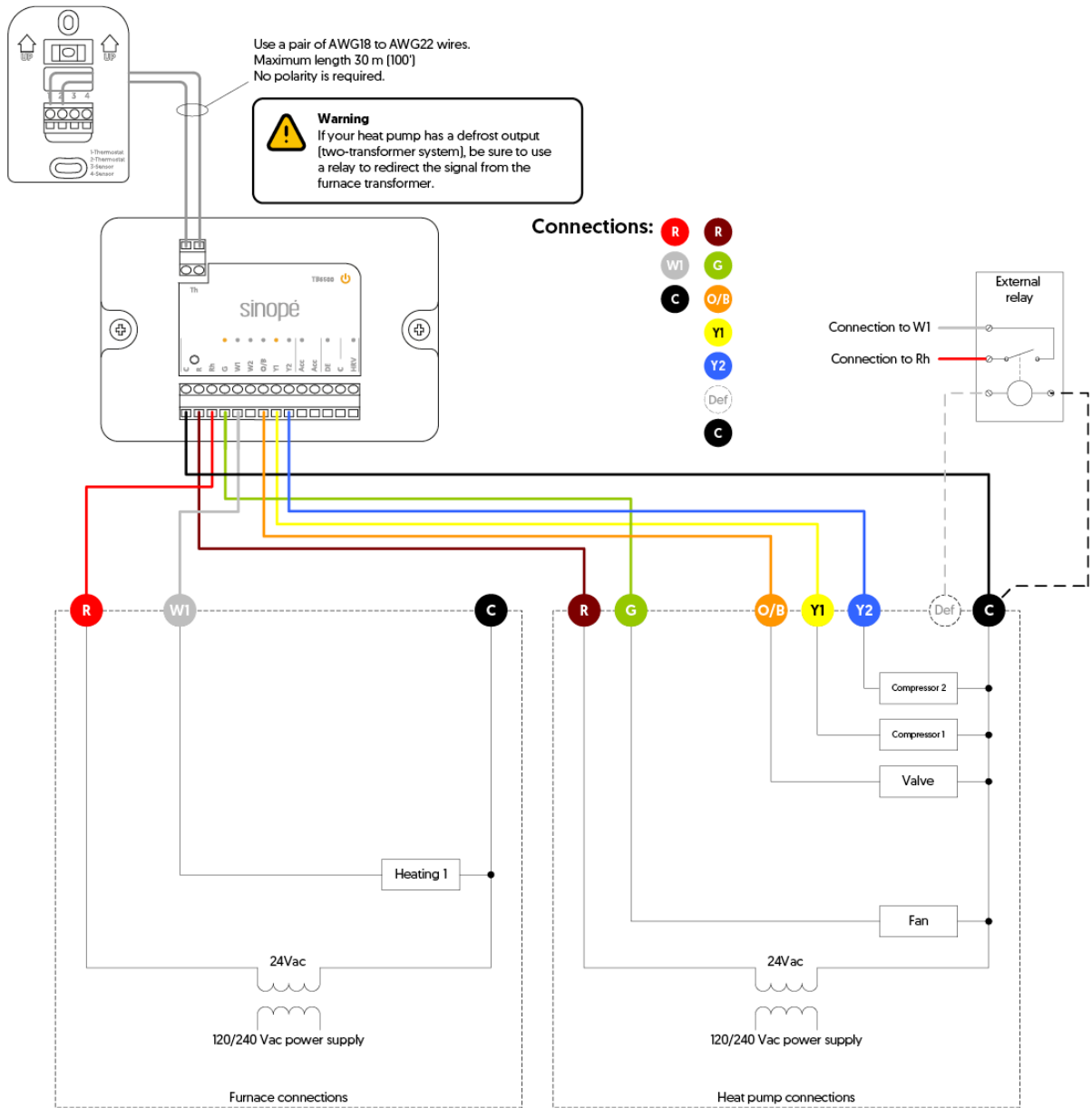

Wiring 22: 4H2C

Refers to an HVAC system with **four heating stages** and **two air conditioning stages** with **ventilation control**. Standard connection for heat pumps.

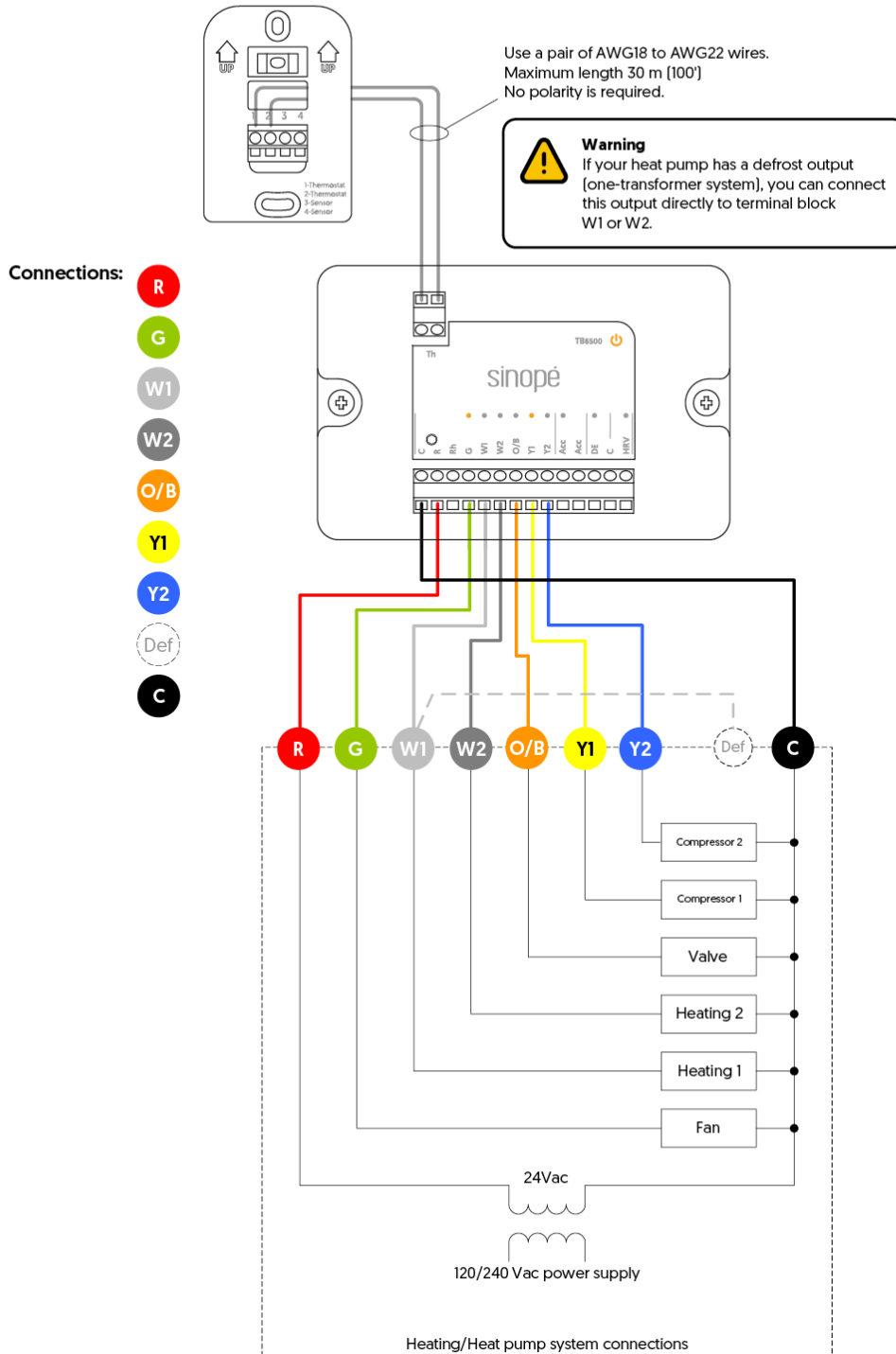

Wiring 23: 4H2C

Refers to an HVAC system with **four heating stages** and **two air conditioning stages** with **ventilation control**. **Separate power for heating and cooling**. Standard connection for a heat pump combined with a furnace.

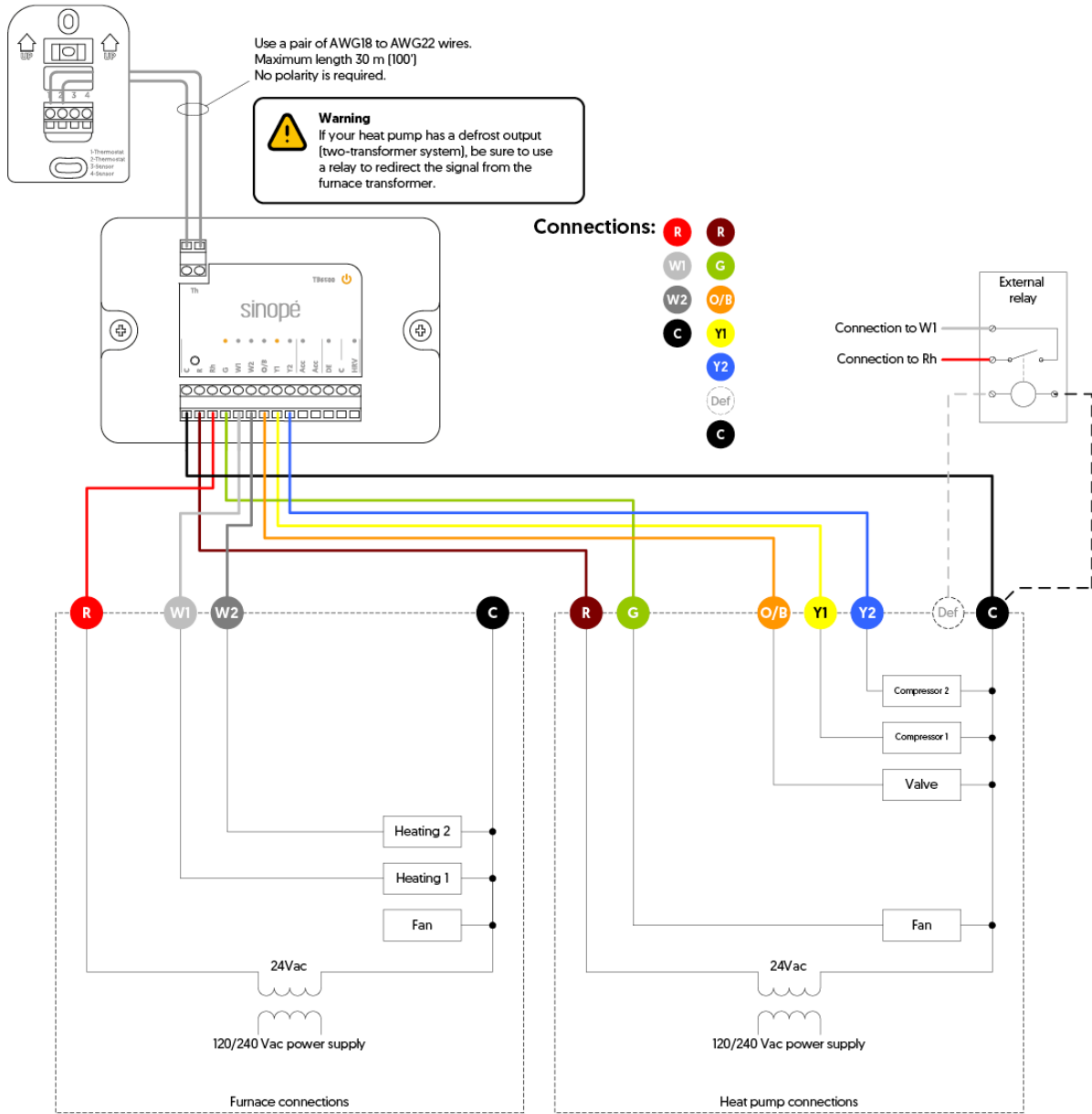

Additional system

Wiring 24: Humidifier / Dehumidifier

Humidifier or dehumidifier powered by the HVAC system.

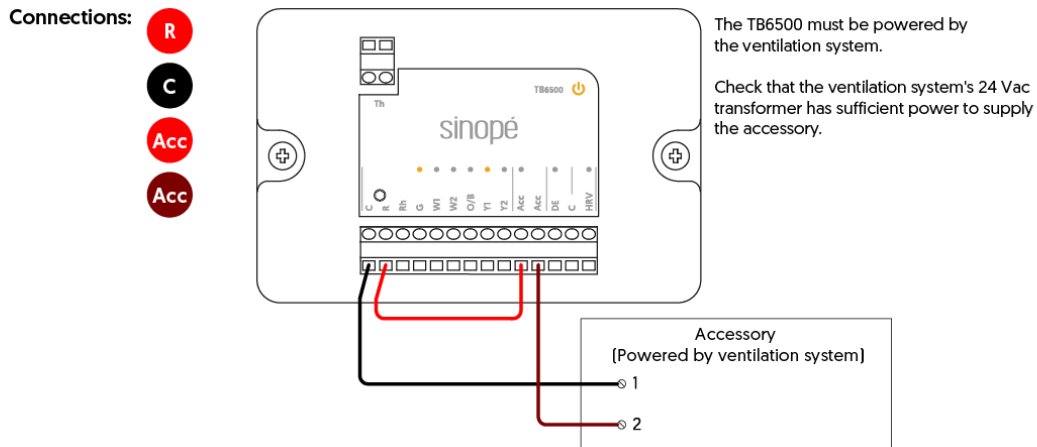

Wiring 24.1: Humidifier / Dehumidifier

Humidifier or dehumidifier with independent external power.

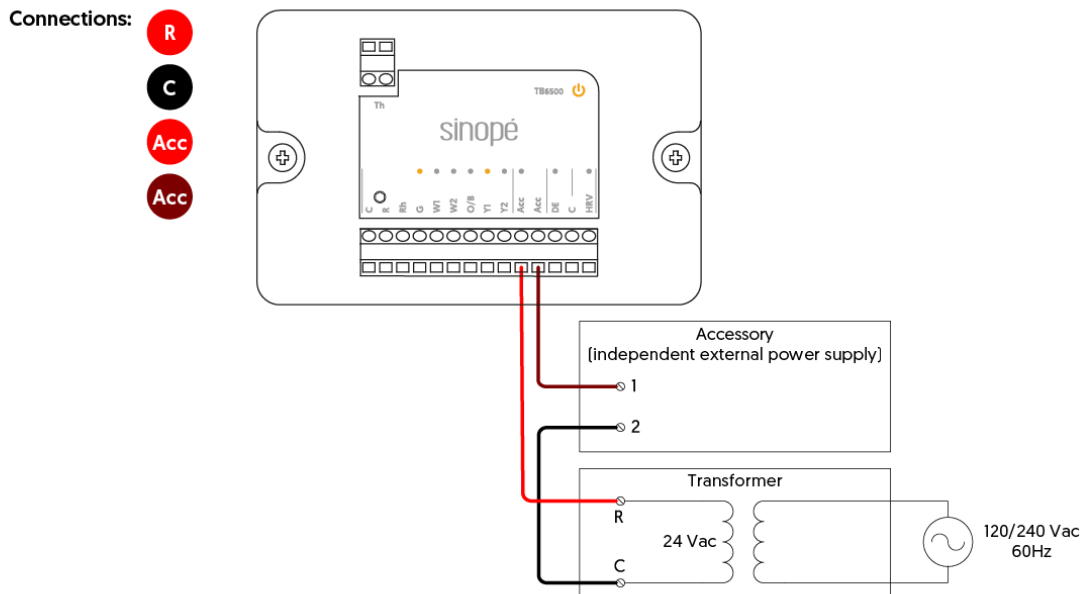

Wiring 24.2: Humidifier

Humidifier or dehumidifier with internal power.

Connections:

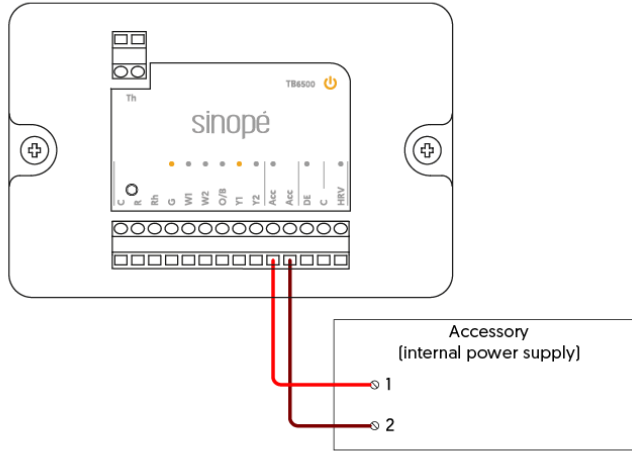

Wiring 24.3: Thermal storage

Thermal storage unit with internal power supply

Connections:

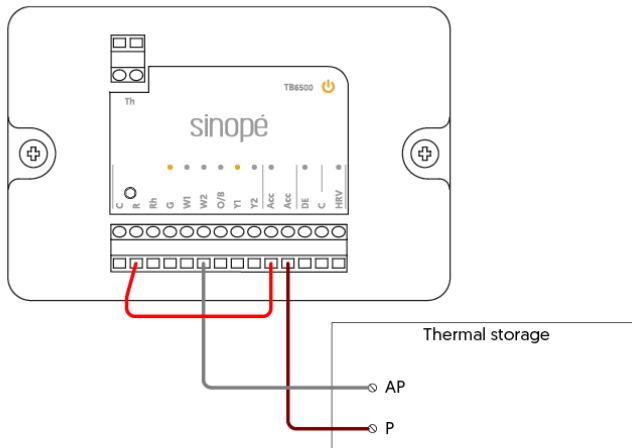

Wiring 25: Air exchanger

Connection for an air exchanger.

The **ACC-ACC** input is a dry contact used to start the air exchanger. The **HRV** input activates the HVAC system's ventilation when a dry contact is established between **HRV** and **C**. It is **not necessary** to connect both **HRV and ACC**: only one of these connection options can be used, depending on the application. If you choose only the C and HRV connection option, no new options will be added to your thermostat menus; the air exchanger will operate independently.

Possible connection options:

- C HRV
- ACC ACC
- ACC ACC C HRV

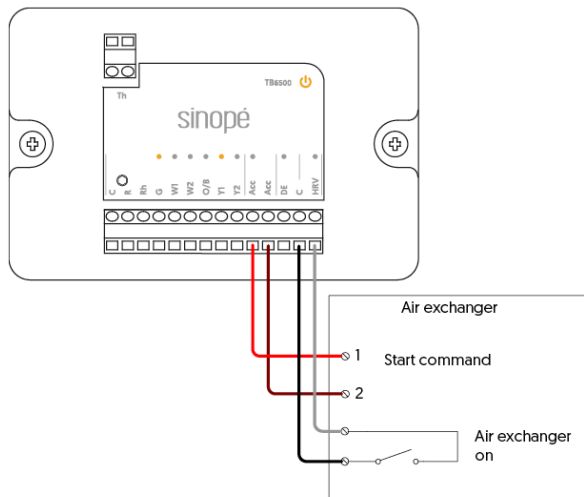

Wiring 26: Dual-energy

Connection for dual-energy signal.

Connections:

- DE
- C

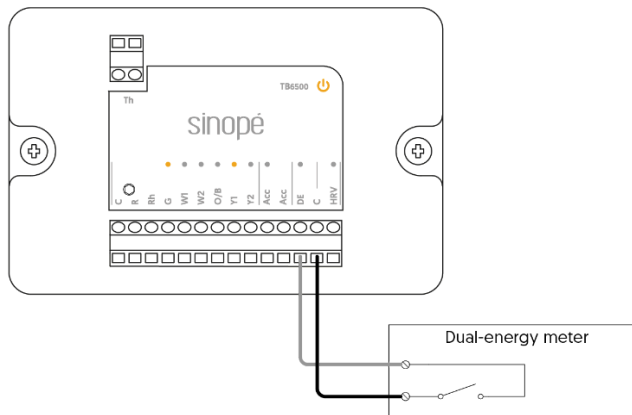

Wiring 27: SSR

Connections: **C**
W1

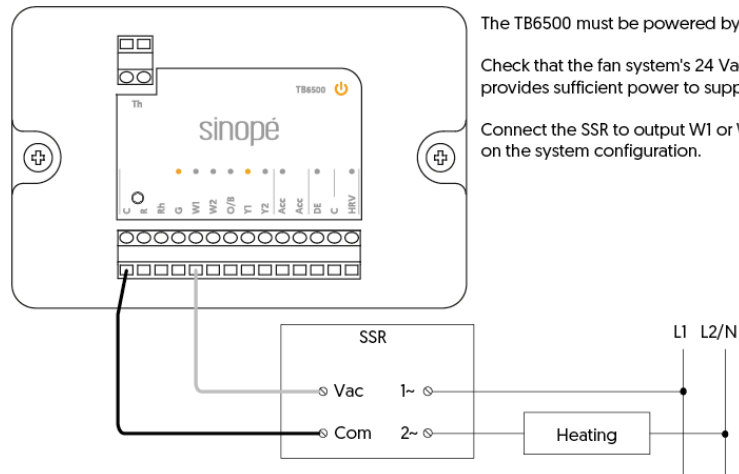

Note: SSR consumption on the output must be at least 20 mA [AC] when the system configuration uses the TB6500 Rh terminal.

Wiring 28: Heat pump "L" output

Connections: **R**
L
C

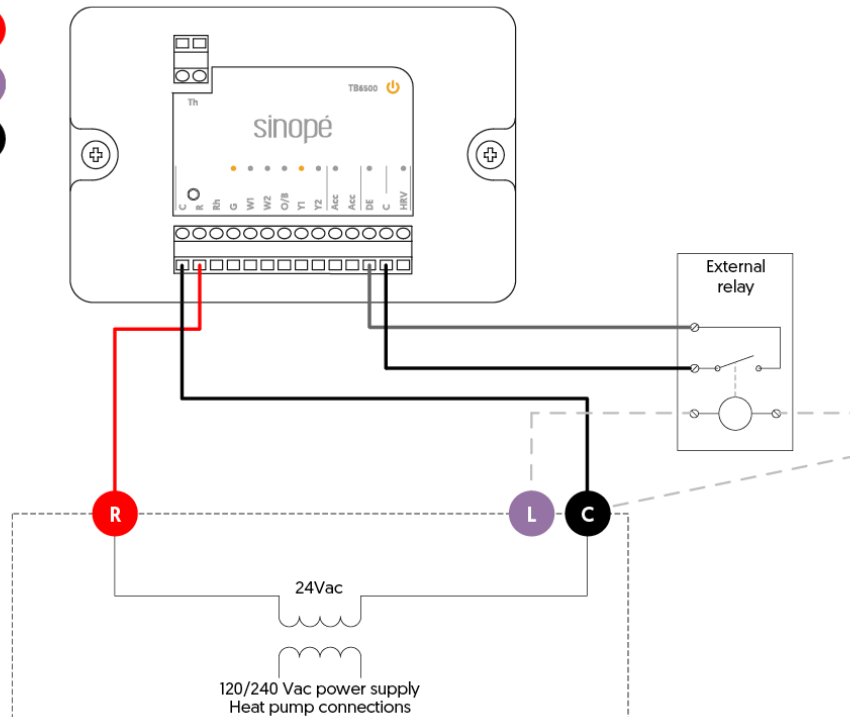

Additional accessories

Decorative mounting plates

Designed to cover wall imperfections from a previous thermostat, these plates also include a steel backing plate for installation over an electrical box.

When a junction box is used, the decorative plate must be installed to ensure adequate and safe coverage.

Decorative mounting plates for the TH6500WF



AC6500-01 Decorative Mounting Plate (sold separately)

Dimensions (W x H x D): 180.5 mm (7.11 in) X 112.5 mm (4.43 in) X 5 mm (0.20 in)

Included in the box:

- Decorative mounting plate
- Steel plate, installation sheet
- 2 screws for the decorative plate
- 2 screws for the steel plate

Installation diagrams for the AC6500-01 decorative mounting plate

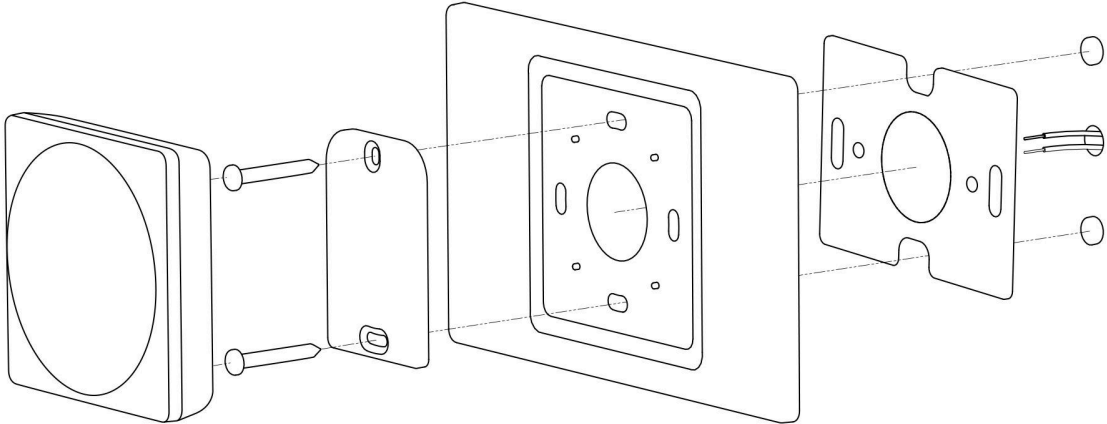
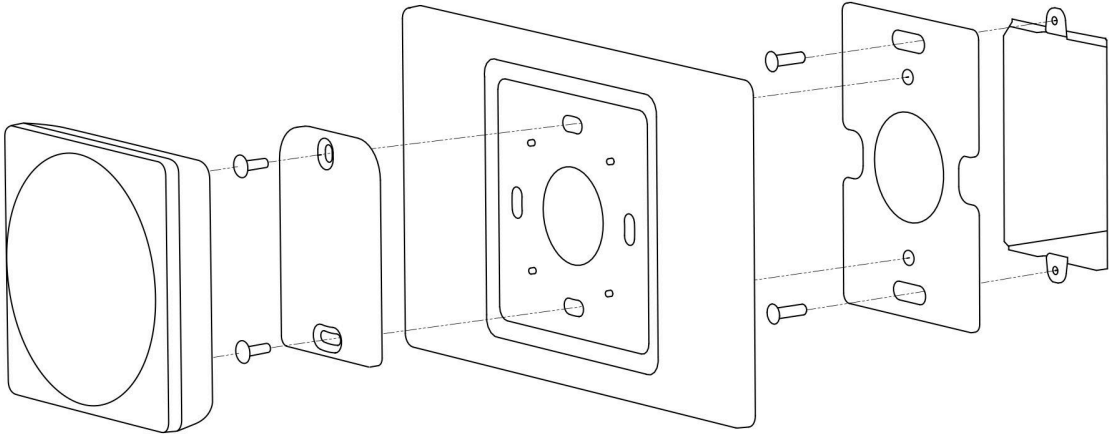



AC6500-02 Decorative Mounting Plate (sold separately)

Dimensions (W x H x D): 114.3 mm (4.5 in) X 114.3 mm (4.5 in) X 4.8 mm (0.19 in)

Included in the box:

- Decorative mounting plate
- Steel plate, installation sheet
- 2 screws for the decorative plate
- 2 screws for the steel plate

Installation diagrams for the AC6500-02 decorative mounting plate

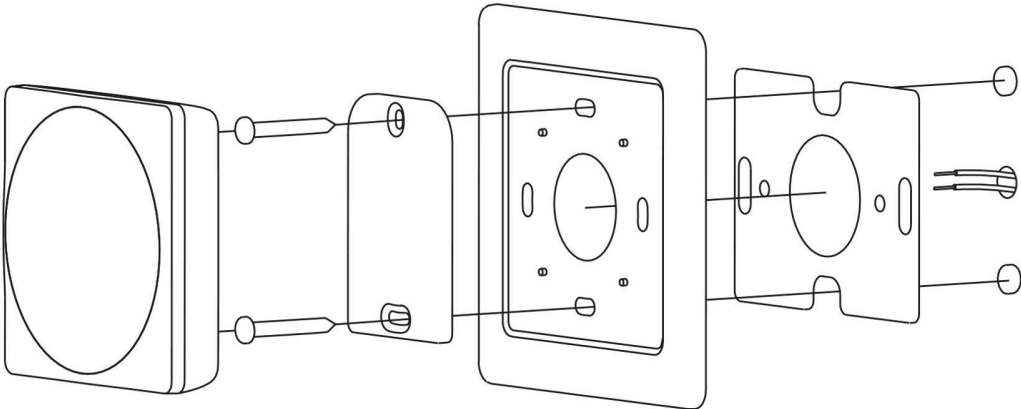
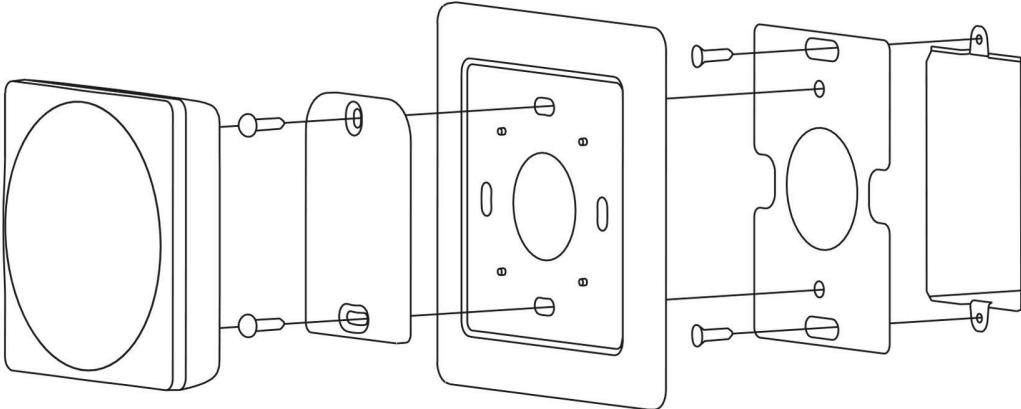

Decorative Mounting Plates for the TH6500WF REV: 01



AC6500-03 Decorative Mounting Plate (sold separately)

Dimensions (W x H x D): 180.5 mm (7.11 in) X 112.5 mm (4.43 in) X 5 mm (0.20 in)

Included in the box:

- Decorative mounting plate
- Steel plate, installation sheet
- 2 screws for the decorative plate
- 2 screws for the steel plate

Installation diagrams for the AC6500-03 decorative mounting plate

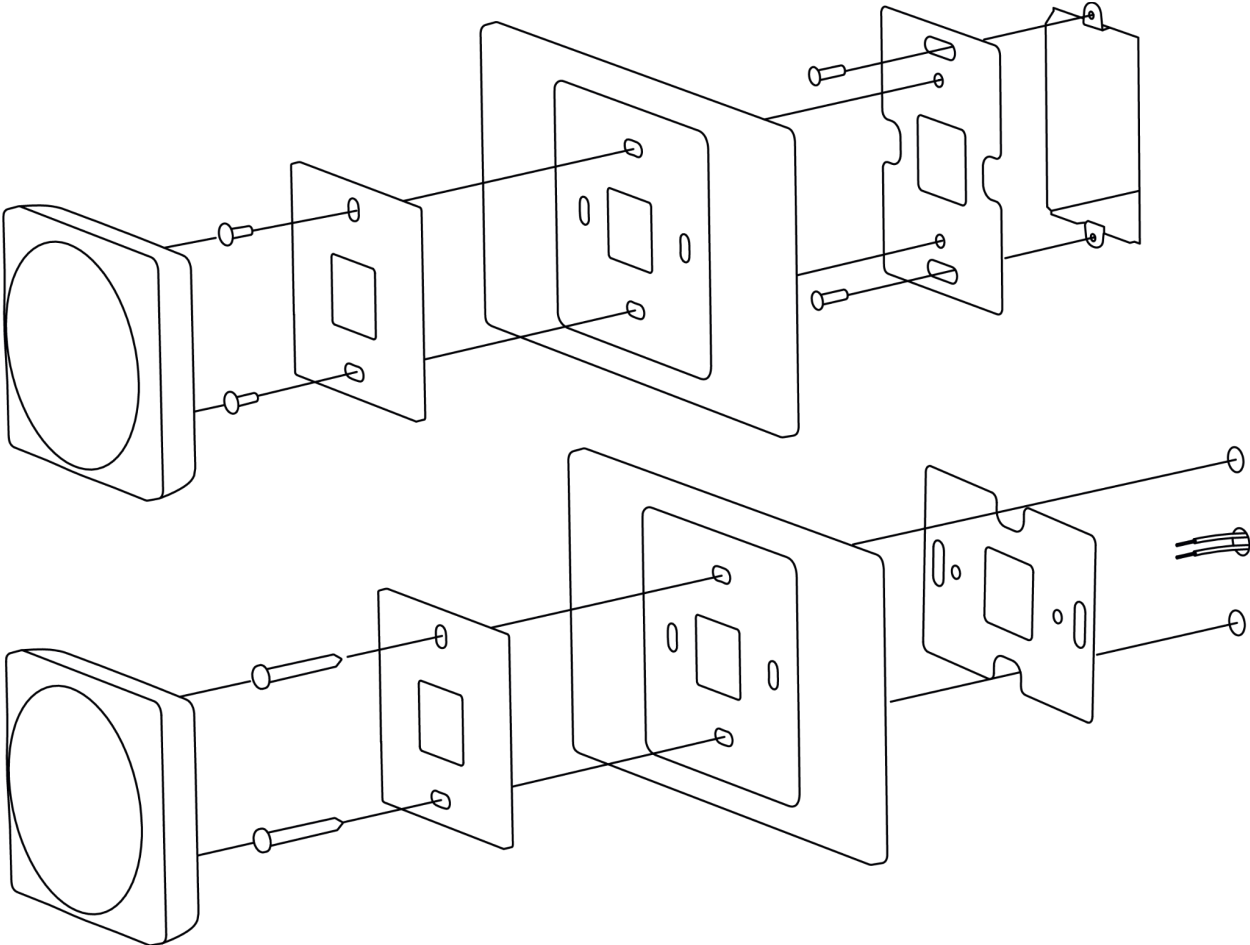



AC6500-04 Decorative Mounting Plate (included)

Dimensions (W x H x D): 114.3 mm (4.5 in) X 114.3 mm (4.5 in) X 4.8 mm (0.19 in)

Included in the box:

- Decorative mounting plate
- Steel plate, installation sheet
- 2 screws for the decorative plate
- 2 screws for the steel plate

Installation diagrams for the AC6500-04 decorative mounting plate

